

Change in color and rheological behavior of pineapple concentrate through various evaporation methods

Rittichai Assawarachan, Athapol Noomhorm

(Food Engineering and Bioprocess Technology, School of Environment, Resources and Development, Asian Institute of Technology, Klongluang, Pathumthani 12120, Thailand)

Abstract: The objective of this study was to investigate the effect of various concentration methods namely microwave vacuum evaporation (MVE), microwave heating evaporation (MHE), and rotary vacuum evaporation (RVE) on the concentrate change, the kinetic of color degradation, and the rheological behavior of pineapple juice. The concentrated behavior of pineapple juice from the experimental data of concentration rate was fitted with three types of exponential models for evaluating a suitable prediction. The four-parameter exponential model was found to agreeably explain the concentrated change of pineapple juice during each concentration methods. The Kinetics of color change during concentration processes was evaluated. The color changing from three different evaporations was measured by lightness values (L^*), redness values (a^*) and yellowness (b^*) values, total color difference (TCD) and brown pigment formation index (A_{420}). The result indicated that the change in Hunter parameters, L^* and b^* , fitted well with the first-order kinetic model while a^* , TCD, and Browning index followed the zero-order kinetic model. The observed apparent viscosities (μ_a) of pineapple concentrate at 55-85°C through the three different evaporation methods were also measured. In relation to temperature and shear rate, the viscosity decreased as these two parameters increased, for all concentrated pineapple juice. On comparing the values of μ_a of pineapple concentrate from different concentration methods, pineapple concentrate from MHE has higher values than those from MVE and RVE. The Duncan test, applied to the experimental results, indicates no significant difference in the μ_a of pineapple juice concentrate by MVE and by RVE.

Keywords: Pineapple juice concentrate, microwave vacuum evaporation, microwave heating, rotary vacuum evaporation, kinetic of color change

DOI: 10.3965/j.issn.1934-6344.2009.04.0-0

Citation: Rittichai Assawarachan, Athapol Noomhorm. Change in color and rheological behavior of pineapple concentrate through various evaporation methods. Int J Agric & Biol Eng, 2009; 2(4): —.

1 Introduction

Pineapple (*Ananas cosmosus*) is one of the most important fruits in food industry^[1]. Pineapple juice is a typical product made from pineapple, which can be sold

as a high value-added product at a premium price. Before shipping to its final destination, fruit juice is usually concentrated for the purpose of a reduction in transportation, packaging, and storage cost. The concentrated fruit juice also ensures a longer storage life to serve a longer commercial operations time, as well as a

Received date: 2009-03-28 **Accepted date:** 2010-03-08

Biographies: Rittichai Assawarachan, Ph.D, Food Engineering and Bioprocess Technology, School of Environment, Resources and Development, Asian Institute of Technology, Klongluang, Pathumthani 12120, Thailand. Email: Rittichai.Assawarachan@gmail.com

Corresponding author: Athapol Noomhorm, Ph.D, Professor, Food Engineering and Bioprocess Technology, School of Environment, Resources and Development, Asian Institute of Technology, Klongluang, Pathumthani 12120, Thailand. Tel: (662) 524-5476, Fax: (662) 524-6200. Email : athapol@ait.ac.th

better conservation due to the water activity reduction^[2]. Although, the multi-stage vacuum evaporation results in the loss of fresh juice flavors and the color degradation due to the thermal effects, this method has been conventionally used in the concentration process these days^[3,4]. During the concentrating process, the water is partially removed in the form of vapor from a boiling solution, while solid compositions such as vitamins, minerals, and sugars do not change. These components in fruit juice are left to the fruit juice concentrate^[5] and the evaporation of water lead to the occurrence of a more concentrated solution. The evaporation rate is affected by operating conditions, types of evaporators, and characteristics of the sample to be evaporated. Microwave energy has the distinct advantage in thermal processing^[6]; as the heat is generated within the food material by the reorientation of the dipoles which in turn causes water molecular friction and generates heat^[7,8]. The application of microwave energy providing rapid heating is already widely used in the food industry.

Vacuum evaporation was performed to avoid high temperature, juice flavor change, and color quality change which is conventionally the results from the thermal effect and long time processing^[9]. Therefore, using microwave assisted vacuum evaporation had many advantages which suit the requirements for optimal concentration process including: rapid rate of heat transfer, low temperature operation through an application of a vacuum, efficient vapor liquid separation, and efficient energy use and recovery. The low temperature and fast mass transfer conferred by a vacuum system, combined with the rapid energy transfer by microwave heating, generate a rapid, low-temperature concentration^[10]. Knowledge of the concentration characteristic of samples which are concentrated is crucial^[11,12] for the design of equipment, the optimization of process, and the improvement of product quality^[13]. It is therefore necessary to use mathematical model in order to control and minimize the concentrating process. Mathematical model of the change in concentration ($^{\circ}$ Brix) of fruit juice is important for the optimization of operation and for the performance improvements of evaporation process. The mathematical models may

help to gain a better understanding of transportation phenomena associated with processing^[14]; and can be used to control or optimize the variables of the dehydration system namely drying process^[15]. Numerous researchers have developed the two and the three-parameter exponential equations to describe the change in the concentration of pomegranate juice through microwave heating^[16], and in pineapple concentrate by way of microwave vacuum evaporation^[17]. Visual color, the first priority of consumers' perceptions, is an important characteristic by which affecting consumer preference of a product, and often accounting for 40% of the criteria for acceptance^[18]. It is also an indicator of pigment concentration which can be measured instantaneously using tristimulus colorimeters for on line quality control. Many reports found that many reactions effect the color occurred during the thermal processing. Among them, the most common ones are pigment degradation, especially carotenoids (lycopene, xanthophylls, *etc.*), anthocyanin, and chlorophyll, and browning reactions such as the Maillard reaction, enzymatic browning, and oxidation of ascorbic acid^[19]. Hunter color parameters (L^* , a^* , b^*) and total color different (TCD) have been widely used to describe the color change during thermal processing of fruit and vegetable products. The work on the concentration of pomegranate juice^[16] reported that Hunter color values changed during heat treatments. In addition many investigators observed similar results in their studies such as thermal treatment of concentrated mango puree, peach puree and tomato paste^[20-22]. Numerous researchers have applied a zero-order and first-order kinetic model to describe the color change and non-enzymatic browning of food during processing fruit products. The previous researches about the kinetic of color change and the non-enzymatic browning reactions during processing a variety of fruit products were investigated such as apple juice and pineapple juice^[23,24].

Viscosity, a vital physical characteristic, involves with the liquid food quality. Viscosity is necessary for the design of equipment, and the process for puree manufacturing, as well as the process incorporated with the puree in manufacturing other food products^[25-27].

Sengül et al.^[28] expressed that the study of viscosity and flow behavior is very complex. There are many factors effecting the flow behavior of non-Newtonian fluids including shear rate, temperature, pressure, moisture content, or solid concentration^[29,30]. Moreover, the rheological behavior is influenced by the changing pH^[31]. The effect of temperature on flow behavior is important in the design of a continuous pasteurizer^[32]. The knowledge of the effect of temperature on viscosity results in a better understanding of the rheological behavior of vegetable and fruit puree during processing at high temperature^[26,27]. However, studies on the kinetics of color change and the rheological behavior of pineapple concentrate through various evaporation processes are lacking. This present study is therefore concentrated on the investigation of the effect of different evaporation processes, which are microwave vacuum evaporator (MVE), microwave heating evaporator (MHE) and rotary vacuum evaporator (RVE), on the production of pineapple juice concentrate. Additionally, the study would emphasize on the kinetics of color change using Hunter color parameter scale (L^* , a^* and b^* values) and the rheological behavior of pineapple juice during evaporation processes.

2 Materials and method

2.1 Preparation of fresh pineapple juice

Pineapple juice was obtained from Siam Agro Industry Pineapple Co.Ltd, Thailand. The juice was then packed in plastic bag at -20°C . And it was defrosted to 30°C at the time of experiment. Before the experiment, the physiochemical characteristics of sample juice which are pH and total acidity were determined with a glass-electrode pH meter and titration with sodium hydroxide to pH 8.0 (AOAC, 1997). Total soluble solids content (TSS) of pineapple juice was measured using a refractometer (ATAGO, Japan) at $(20\pm 1)^{\circ}\text{C}$ and was expressed in $^{\circ}\text{Brix}$. The color parameters of pineapple juice were measured by Hunter Lab D25-PC2 colorimeter (Hunter Associates Laboratory Inc., Reston, VA, USA) in terms of lightness (L^*), redness (a^*), and yellowness (b^*). The physiochemical characteristics of the pineapple juice are presented in Table 1.

Table 1 Physiochemical characteristic of fresh pineapple juice

| Physiochemical Characteristic | Value |
|--|------------------|
| Total soluble solid, TSS ($^{\circ}\text{Brix}$) | 12.26 ± 0.23 |
| pH | 3.65 ± 0.38 |
| Total Acidity (g citric acid/100 g) | 0.58 ± 0.04 |
| TSS/TA ratio | 20.20 ± 0.18 |
| Color | |
| Lightness (L^*) | 36.28 ± 0.08 |
| Redness (a^*) | -1.80 ± 0.04 |
| Yellowness (b^*) | 3.84 ± 0.05 |

Note: Mean ($n=3$) \pm standard error of estimation.

2.2 Pineapple juice concentration methods

Pineapple juices were concentrated by three different evaporation processes. A 200 ml of pineapple juice placed in one-liter evaporation flask was concentrated from the initial of 12°Brix to the final of 60.5°Brix .

2.2.1 Rotary Vacuum Evaporator (RVE)

A 200 g of pineapple juice with an initial total soluble solid of 12.2°Brix was put in a round bottom flask and was concentrated by laboratory rotary vacuum evaporator (EL-131 model Büchi, Switzerland) under 200 mbar vacuum pressure until obtaining the desired final concentration of 60.5°Brix . During the evaporation process, the sample was heated by immersing it in a 55°C water bath warmed by a 1500 Watt electrical power heater.

2.2.2 Microwave Heating Evaporator (MHE)

The juice sample was concentrated in a domestic microwave oven (Turbora Model TRS-2039) which has a multimode stainless steel microwave cavity ($55\text{ cm} \times 30\text{ cm} \times 35\text{ cm}$). The microwave's power was adjusted from 0 to 750 W at 2.45 GHz.

2.2.3 Microwave Vacuum Evaporator (MVE)

The microwave vacuum evaporator was designed and fabricated in Food Engineering workshop, Asian Institute of Technology. The schematic diagram of microwave vacuum is shown in Figure 1. Modified rotary vacuum as above mentioned was installed together with the standard microwave oven (Turbora Model TRS-2039). From the trials with different power input of microwave, MVE was finally set at 185 W, which was the most suitable power because it does not cause an over boiling from foaming and charring problem of pineapple juice^[17].

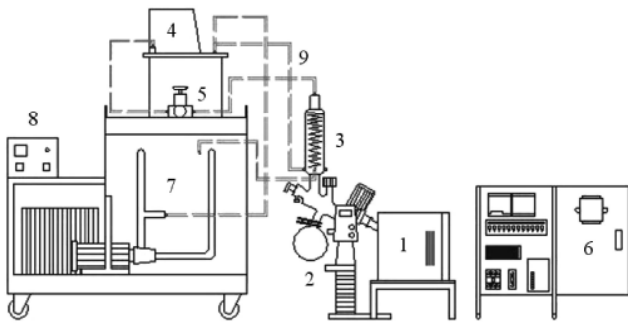

1.Microwave oven 2.Rotary vacuum 3.Condenser tower 4.Vacuum pump
5.Vacuum regulator 6.PLC-controller 7.Cooling tank 8.Temperature controller 9.Cooling line

Figure 1 Schematic of the microwave vacuum concentration system

The relationship between the change of TSS and times was fitted to the two-parameter, the three-parameter, and the four-parameter exponential in order to describe the concentration behavior of pineapple juice concentrate produced by microwave-vacuum evaporator. The parameters of all models were estimated by using SPSS software. Concentration curves, obtained from TSS of pineapple juice during MVE, were tested to select the best model for describing the concentrated curve of pineapple juice.

Two parameter exponential

$$B = B_0 + \exp(kt) \quad (1)$$

Three parameter exponential

$$B = B_0 + B_1 \exp(kt) \quad (2)$$

Four parameter exponential

$$B = B_0 + B_1 \exp(kt^n) \quad (3)$$

Where, B and B_0 are the soluble solid concentration of pineapple juice at any time and the initial concentration, respectively; B_1 is a constant model; k is evaporation rate (min^{-1}); n is consistency of model and t is concentrated times (min).

The statistical parameters were used to select the best model for describing concentration curve. The accuracy of the model was measured by three statistical values, namely the coefficient of determination (R^2), chi-square (χ^2), and relative percentage error, PE(%). The value of R^2 means the better quality of curve fitting. In addition, the value of χ^2 and PE (%) were used to consider the difference between the experimental and the predicted data. Conversely, the decrease of χ^2 and PE(%) shows the better model. These three parameters can be calculated as the procedure of many author^[33-37] which

was given below:

$$R^2 = 1 - (\text{Residual SS}) / (\text{Corrected total SS}) \quad (4)$$

$$\chi^2 = \frac{\sum (\Delta B_{\text{exp},i} - \Delta B_{\text{pred},i})^2}{N - n_p} \quad (5)$$

$$PE(\%) = \frac{100}{N} \sum_{i=1}^n \frac{|\Delta B_{\text{exp},i} - \Delta B_{\text{pred},i}|}{\Delta B_{\text{exp},i}} \quad (6)$$

Where, $\Delta B_{\text{exp},i}$ and $\Delta B_{\text{pred},i}$ are the experimentally observed and the predicted concentration change in term of °Brix, respectively; N is the number of observations and n_p is the number of constants in the model.

2.4 Determination of quality parameters.

2.4.1 Color measurement

The color measurements of pineapple juice were carried out using Hunter lab colorimeter, after calibration with black and white standard tiles ($L^* = 93.33$, $a^* = 0.91$, $b^* = 1.46$) and distilled water ($L^* = 100$, $a^* = 0$, $b^* = 0$) each time. 50 g of each pineapple juice samples were placed into a standard glass container and read at opponent color scales: L^* (100 = bright, 0 = dark), a^* (positive = red, negative = green), and b^* (positive yellow, negative = blue).

2.4.2 Determination of non-enzymatic browning index

Methods as mentioned in Cohen et al.^[12] were used to determine the non-enzymatic browning index of concentrated pineapple juice. A 5 ml of 95% ethyl alcohol was introduced into a 5 mL of pineapple juice. The mixture was centrifuged at 1000 g for 15 min. The supernatant of the centrifuged sample was taken to measure the absorbency at 420 nm for the non-enzymatic browning index using a spectrophotometer.

2.4.3 Rheological measurements

Apparent viscosity (μ_a) of pineapple concentrate juice (60.5°Brix) was carried out using rotational type Brookfield Viscometer (Brookfield Engineering Laboratories: Model RVDV-II+P model, WA, USA). A sample of 500 mL of pineapple concentrate was contained in a 600-mL glass beaker for all experiments. Differences of temperature level of the samples at 55, 65, 75 and 85°C were regulated using a water bath which is temperature controlled by Symax PID controller (accuracy $\pm 0.1^\circ\text{C}$). The measurement range (between 10% to 100% full scale torque) of LVDV-II Brookfield

Viscometer was adjusted by selection of specific spindles (S-61; S-62; S-63; S-64) and rotational speeds (1 to 100 rpm) for various concentrations of juice.

2.4 Statistical analysis

One way analysis of variance (ANOVA) was performed to determine the quality change of concentrated pineapple juice through three concentration processes. Each measurement was replicated three times. Experimental data for the different kinetic models was analyzed using statistic program.

3 Results and discussion

3.1 Concentration change during evaporation process

Vacuum evaporation process has the advantage of highly efficient technology, and provides high product quality. The vacuum evaporation is an unit operation in fruit juice processing; by this process, the fruit juice product is evaporated with higher quality than by the conventional process at atmospheric pressure under sub-atmospheric pressures because it can be operated at low temperature. Figure 2 represents the relationship between the evaporation time and the total soluble solid (TSS) of pineapple concentrate from various evaporation processes: microwave vacuum evaporation (MVE), microwave heating evaporation (MHE), and rotary vacuum evaporation (RVE). All experimental data from the three evaporation techniques has evaporation behavior shown in the exponential type.

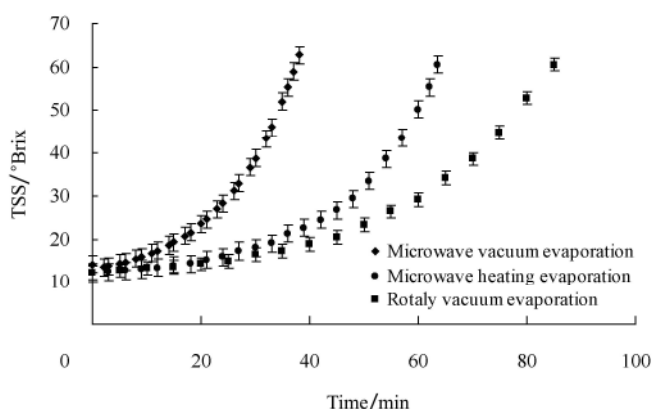

Figure 2 Changes in pineapple concentration produced by three different evaporation processes

The time required to concentrate pineapple juice from the initial concentration of 12.2°Brix to the final concentration of 60.79±0.39°Brix was achieved in 23, 38

and 50 minutes by using MVE, MHE and RVE, respectively. The evaporation rate constant (k) for MVE was 1.65 and 2.18 times greater than those of MHE and RVE, respectively. Microwave vacuum applied in evaporation process has the advantage of highly efficient technology because it can improve the energy efficiency and the product quality. The average total soluble solid of pineapple juice data observed in term of °Brix during concentration process by different methods was analyzed using non linear regression techniques. In the present study, the evaporation behavior of pineapple juice during evaporation process can be described in term of exponential model^[16,17]. Microwave power had an important effect on evaporation. At higher microwave power, due to the quick removal of water, the evaporation time was reduced.

3.2 Evaluation modeling of vacuum microwave evaporation of pineapple juice concentrate

The concentrations of pineapple juice at various microwave power were fitted in three type exponential models. And the results of statistical analysis are shown in Table 2. In all cases, the value of R^2 was greater than 0.95 indicating a good fit. The goodness of fitting curve of different mathematic models at various microwave power was evaluated based on a higher coefficient of determination (R^2), a lower Chi square (χ^2), and a lower percentage error, PE (%). For all experiments, the R^2 , χ^2 and PE (%) values for the models are between 0.9782 and 0.9987; 0.0881 and 3.8246; 1.06% and 6.72%, respectively. It was observed that when the four-parameter exponential model were used, it provided the highest R^2 values, the lowest χ^2 , and RMSE than those of other models. In addition, relative percentage error, PE (%) was used to consider the difference between the experimental and the predicted data, the relative percentage error below 10% indicates the goodness of fitting^[38]. It was determined that the four-parameter exponential model is the best description of the concentrated behavior change of pineapple juice during MVE because this model gave highest R^2 and low statistical error parameter, namely χ^2 and PE (%) values which are less than those of the two and the three-parameter exponential models.

Table 2 Coefficients for mathematical models and errors in concentrate change prediction model of three different evaporation processes

| Mathematical model | Microwave power (W) | Coefficient and Statistical | | | | Statistical Error Parameter | | |
|-----------------------------|---------------------|--|-----------------|-----------------|---|-----------------------------|----------|---------|
| | | $k \pm SE$ ($\text{min}^{-1} \times 10^{-2}$) | $n \pm SE$ | $B_1 \pm SE$ | $B_0 \pm SE$ ($^{\circ}\text{Brix}$) | R^2 | χ^2 | $PE/\%$ |
| Two parameter exponential | MHE | 6.102 ± 0.01 | | | 11.40 ± 0.13 | 0.9891 | 0.7688 | 3.93% |
| | RVE | 4.603 ± 0.01 | | | 12.46 ± 0.37 | 0.9823 | 1.5852 | 4.26% |
| | MVE | 10.35 ± 0.02 | | | 14.24 ± 0.09 | 0.9782 | 3.8246 | 6.72% |
| Three parameter exponential | MHE | 3.75 ± 0.10 | | 2.08 ± 0.18 | 11.51 ± 0.06 | 0.9927 | 0.2922 | 1.59% |
| | RVE | 6.16 ± 0.12 | | 0.96 ± 0.07 | 11.51 ± 0.06 | 0.9919 | 0.2644 | 1.89% |
| | MVE | 8.79 ± 0.26 | | 1.81 ± 0.45 | 11.82 ± 0.22 | 0.9974 | 0.2441 | 1.18% |
| Four-parameter exponential | MHE | 6.18 ± 1.53 | 1.06 ± 0.06 | 0.75 ± 0.14 | 11.73 ± 0.18 | 0.9978 | 0.1385 | 1.08% |
| | RVE | 2.91 ± 3.62 | 1.07 ± 0.22 | 1.68 ± 1.32 | 11.34 ± 1.35 | 0.9977 | 0.1645 | 1.09% |
| | MVE | 7.53 ± 0.13 | 1.01 ± 0.04 | 2.75 ± 0.42 | 11.02 ± 0.62 | 0.9987 | 0.0881 | 1.06% |

Note: Data are expressed as mean \pm standard deviation ($n=3$).

The R^2 , χ^2 and PE (%) values of the four-parameter exponential model vary between 0.9977–0.9987, 0.0881–0.1645, and 1.06%–1.09%, respectively. Therefore, this model gave a better prediction than the other models and may be assumed to present the evaporation behavior

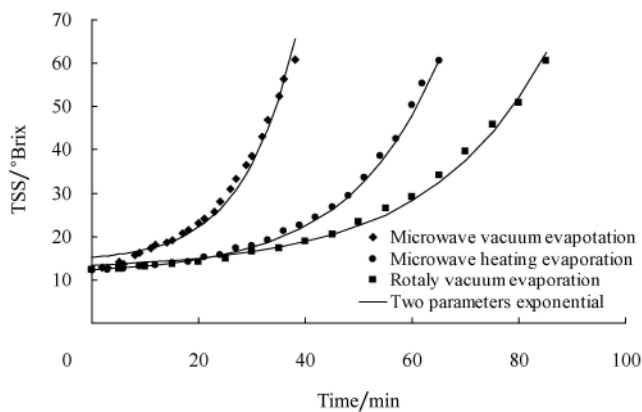

Figure 3 Effects of evaporation methods on concentrated curve and simulation of concentrated curve by using two parameter exponential models

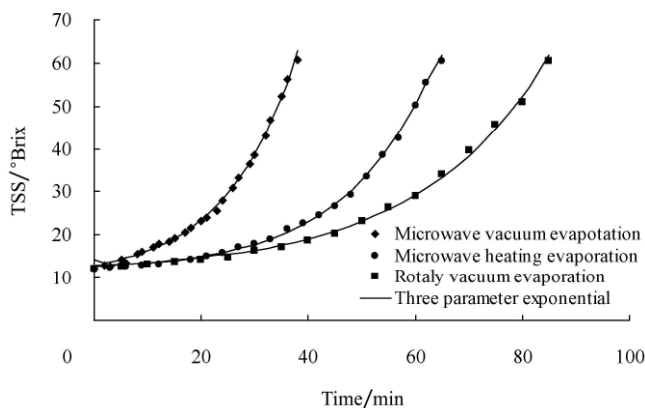

Figure 4 Effects of evaporation methods on concentrated curve and simulation of concentrated curve by using three parameter exponential models

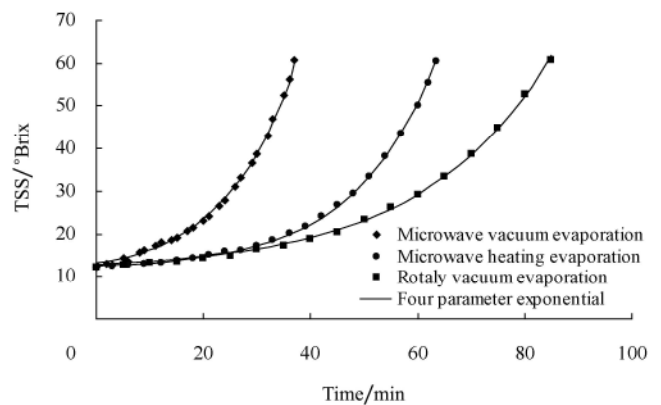

Figure 5 Effects of evaporation methods on concentrated curve and simulation of concentrated curve by using four parameter exponential models

of pineapple juice concentrate during evaporation using MVE. According to these results, they showed the suitability of the four-parameter exponential model in describing vacuum microwave concentration behavior of the pineapple concentrate.

3.3 Change in color parameters during evaporation process

The color degradation of pineapple concentrate by three different evaporation processes affected by the microwave power was investigated using Hunter parameters. Hunter color ratios are the basic criterion for quality consideration of production of pineapple concentrate. The lightness ratio and yellowness ratio are the major color parameters for quality determination of pineapple juice. The same analysis, a characterized variation of color can be illustrated in total color difference (TCD) which is the most important index for

establishing a color change system of pineapple juice. Triplicate measurements were used for each determination. It was calculated by using the following formula:

$$TCD = \sqrt{(L_0 - L^*)^2 + (a_0 - a^*)^2 + (b_0 - b^*)^2} \quad (7)$$

Where, L_0 , a_0 and b_0 represented the reading at time zero; L^* , a^* and b^* represented the instantaneous individual readings during thermal treatment.

Table 3 Kinetic parameters of zero and first order for hunter color change of pineapple concentrate

| Parameter | Kinetic model | Temperature evaporation | $C_0 \pm SD$ | $k_0 \times 10^{-2}/\text{min}^{-1}$ | $k_1 \times 10^{-2}/\text{min}^{-1}$ | R^2 |
|------------------|---------------|-------------------------|---------------|--------------------------------------|--------------------------------------|--------|
| Lightness | First order | MHE | 33.997± 0.341 | | 0.141 | 0.9962 |
| | | RVE | 34.951± 0.128 | | 0.064 | 0.9892 |
| | | MVE | 36.191± 0.032 | | 0.033 | 0.9573 |
| Redness | Zero order | MHE | -1.767± 0.036 | 3.771 | | 0.9991 |
| | | RVE | -1.801± 0.012 | 1.958 | | 0.9899 |
| | | MVE | -1.827± 0.007 | 0.724 | | 0.9895 |
| Yellowness | First order | MHE | 3.635± 0.054 | | 0.420 | 0.9868 |
| | | RVE | 3.862± 0.013 | | -0.108 | 0.9856 |
| | | MVE | 3.904± 0.002 | | -0.082 | 0.9901 |
| TCD | Zero order | MHE | 55.163± 0.109 | 25.341 | | 0.9305 |
| | | RVE | 54.058± 0.057 | 14.337 | | 0.9189 |
| | | MVE | 56.172± 0.287 | 8.365 | | 0.8704 |
| A ₄₂₀ | Zero order | MHE | 0.094± 0.023 | 18.362 | | 0.9032 |
| | | RVE | 0.064± 0.014 | 5.614 | | 0.8955 |
| | | MVE | 0.051± 0.016 | 2.337 | | 0.9217 |

Note: Data are expressed as mean ± standard deviation (n=3).

Lightness ratio (L^*/L_0) is the parameter that measures lightness in pineapple juice and indicates degradation during evaporation process. The change in lightness values during the three different evaporation processes is showed in Figure 6. The first-order kinetic constants (k_1) of lightness values found during MVE, RVE and MHE were 0.033 ± 0.01 , 0.064 ± 0.01 and 0.141 ± 0.03 respectively, as shown in Table 5. With increasing temperature and time in all processes, juice became darker which corresponded to the decrease in L^*/L_0 . The decrease in L^*/L_0 might be influenced by an increase in a^* value and by a decrease in b^* value; and correlated well with an increase in the browning of food material. This relationship followed the first-order kinetic reaction and was similar to the pineapple puree behavior^[11]. Consequently, MVE was proved as the most effective method for maintaining lightness of pineapple juice, whereas RVE and MHE were less effective because of their long overheating period at high temperature causing an increment in browning reaction. The relative yellow color pigment decreased as time and temperature increased during the evaporation through three different methods as shown in Figure 7. The relative visual

yellow color decreased during MVE and RVE as the time progressed. On the other hand, the relative visual yellow color increased by MHE. Evaporation by MHE takes place at boiling temperature of pineapple juice which is $104 \pm 1^\circ\text{C}$ because pineapple juice concentration by MHE was performed without vacuum system. At the same temperature, it therefore cannot be compared with the MVE and RVE which both occur under the vacuum system. Contrary to MVE and RVE, yellow color occurring during MHE is increasing with time. Because of a much higher evaporation temperature of MHE than those of MVE and RVE, the pineapple pulp is burnt to reddish brown. Moreover, sugar in pineapple juice is caramelized when it receives high temperature condition. This makes color of pineapple juice change to orangish red. Interpretation of yellow color in MHE pineapple concentrate does not accurate. Similar results for the decrease in yellow pigment were found by many authors in the studies of color change during thermal process such as concentrated peach puree, tomato paste, pomegranate juice concentrate and pineapple juice^[16,21,24,39]. Decrease in yellow color pigment is fitted well with the first-order kinetic model at 95% confident interval

(Figure 8). Total color difference increases with time and temperature as shown in Figure 9. In this current study, it was observed that the zero-order kinetic model fitted well with TCD. Change in the relative absorbency at 420 nm (A_{420}) which is related to brown pigment formation was adequately described by zero-order kinetic model is showed in Figure 10. The same order of reaction was found by Barreiro et al.^[39] in double

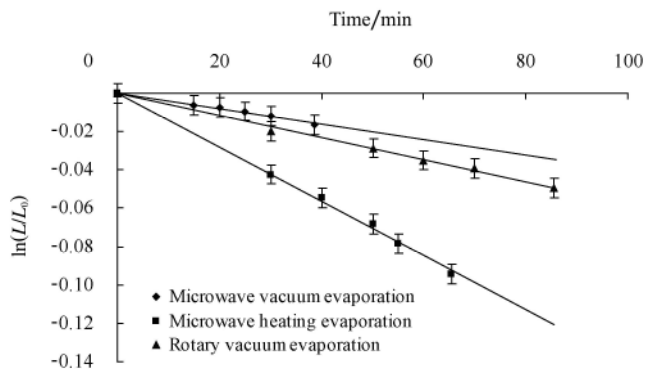

Figure 6 First-order kinetic plots of lightness value changes during concentration of pineapple juice by three different evaporation processes

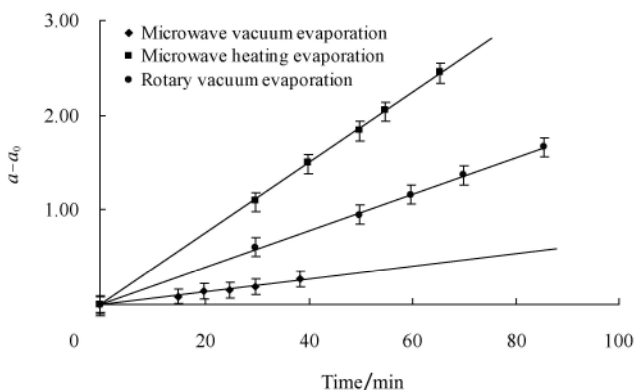

Figure 7 Zero-order kinetic plots of redness value changes during concentration of pineapple juice by three different evaporation processes

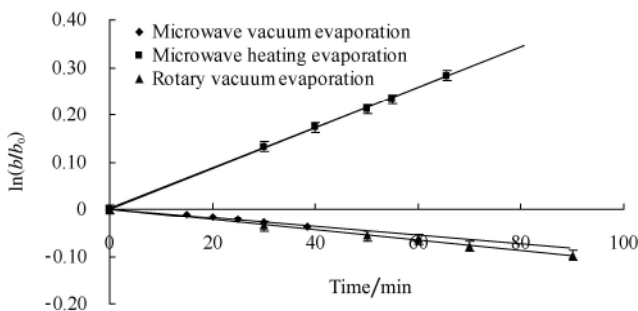

Figure 8 First-order kinetic plots of yellowness changes during concentration of pineapple juice by three different evaporation processes

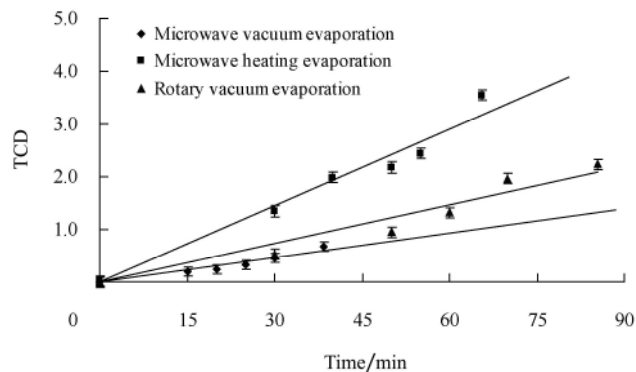

Figure 9 Zero-order kinetic plots of TCD value changes during concentration of pineapple juice by three different evaporation processes

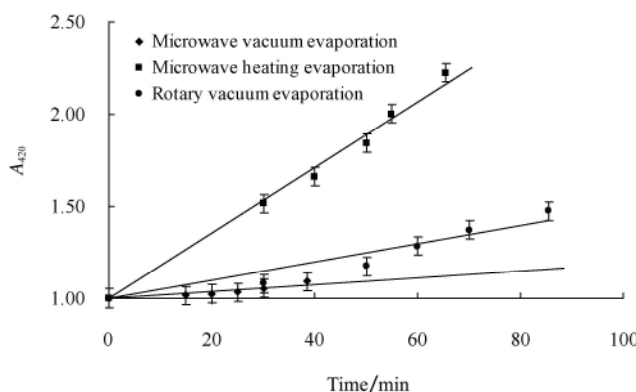

Figure 10 Zero-order kinetic plots of non-enzymatic browning index value (A_{420}) change during concentration of pineapple juice by three different evaporation processes

concentrated tomato paste. In all cases a significant ($p < 0.05$) linear regression with R^2 between 0.973 and 0.990 was obtained. Similar results for the order of reaction were found by other authors in peach puree, pear puree and apple juice^[5,25,40]. Koca et al.^[41] also determine a zero order reaction kinetic model of carrots slices.

3.4 Rheological behavior of pineapple juice

Table 4 represents the relationship between apparent viscosity (μ_a) and shear rate of pineapple juice at 55–85°C during three different evaporation methods. In relation to temperature and shear rate, the viscosity decreased as these two parameters increased, for all concentrated pineapple juice. The decrease in μ_a along with the increasing shear rate can be explained by structural breakdown of the blend due to the hydrodynamic forces generation and the increased

alignment of the constituent molecules such as sugar, oil and protein. On comparing the values of μ_a pineapple concentrate from different concentration methods, pineapple concentrate from MHE has higher values than MVE and RVE. The Duncan test, applied to the experimental results, indicates no significant difference of the μ_a of pineapple juice concentrate by MVE and by

RVE because they have the same total solid soluble and percentage of solid. The cause of these phenomena can be explained that both vacuum evaporation, MVE and RVE, have low evaporation temperature. On the other hand, the pineapple concentrate from MHE is operated at $(104\pm 1)^\circ\text{C}$ which provides high μ_a .

Table 4 Comparisons concentrated methods of apparent viscosity of pineapple juice concentrate at different speeds and temperatures

| Concentration process | Speed /r · min ⁻¹ | Appearance viscosity (mPa s) ⁿ | | | |
|------------------------------|------------------------------|---|----------------------------|----------------------------|----------------------------|
| | | 55°C | 65°C | 75°C | 85°C |
| Rotary vacuum evaporation | 1 | 248.44±1.12 ^{a,A} | 208.93±2.24 ^{a,B} | 181.12±1.24 ^{a,C} | 164.38±0.72 ^{a,D} |
| | 5 | 243.84±0.25 ^{a,A} | 206.25±1.36 ^{a,B} | 180.23±0.23 ^{a,C} | 162.56±1.65 ^{a,D} |
| | 10 | 241.82±1.36 ^{a,A} | 204.54±0.28 ^{a,B} | 180.55±3.48 ^{a,C} | 157.69±0.94 ^{a,D} |
| | 50 | 242.84±0.25 ^{a,A} | 199.25±1.36 ^{a,B} | 178.23±0.23 ^{a,C} | 154.56±1.65 ^{a,D} |
| | 100 | 238.82±1.36 ^{a,A} | 197.54±0.28 ^{a,B} | 173.55±3.48 ^{a,C} | 147.69±0.94 ^{a,D} |
| Microwave vacuum evaporation | 1 | 243.02±2.64 ^{a,A} | 202.00±0.63 ^{a,B} | 193.33±4.16 ^{a,C} | 164.73±2.35 ^{a,D} |
| | 5 | 240.93±1.84 ^{a,A} | 201.42±2.36 ^{a,B} | 185.93±1.36 ^{a,C} | 162.91±3.26 ^{a,D} |
| | 10 | 235.33±1.52 ^{a,A} | 200.13±0.75 ^{a,B} | 184.33±0.11 ^{a,C} | 158.86±0.67 ^{a,D} |
| | 50 | 230.93±0.75 ^{a,A} | 200.06±1.51 ^{a,B} | 180.93±5.93 ^{a,C} | 162.91±1.24 ^{a,D} |
| | 100 | 228.33±0.11 ^{a,A} | 196.13±1.17 ^{a,B} | 171.33±0.11 ^{a,C} | 158.86±1.67 ^{a,D} |
| Microwave evaporation | 1 | 364.25±1.14 ^{b,A} | 312.63±0.25 ^{b,B} | 279.94±1.25 ^{b,C} | 256.52±1.08 ^{b,D} |
| | 5 | 364.22±2.05 ^{b,A} | 304.56±1.28 ^{b,B} | 281.26±0.56 ^{b,C} | 252.56±3.35 ^{b,D} |
| | 10 | 362.63±2.45 ^{b,A} | 302.56±0.94 ^{b,B} | 272.35±0.15 ^{b,C} | 260.44±2.35 ^{b,D} |
| | 50 | 352.24±1.37 ^{b,A} | 300.83±2.05 ^{b,B} | 270.65±1.83 ^{b,C} | 250.95±1.28 ^{b,D} |
| | 100 | 350.38±0.82 ^{b,A} | 291.74±1.25 ^{b,B} | 265.74±2.35 ^{b,C} | 248.33±0.35 ^{b,D} |

Note: Data are expressed as mean ± standard deviation ($n=3$); ^{a, b, c} Mean values followed by the different letter in the same row and ^{A, B, C, D} mean values followed by the different letter in the same column are significantly different ($P\leq 0.05$).

For the reason that, pineapple concentrate from MHE has operated at high evaporation temperature, it resulted in the caramelization reaction. Therefore, sugar in pineapple juice was caramelized leading to the increase in μ_a of carrot juices^[42]. In addition, the production of the pineapple concentrated juice in high temperature by MHE caused larger particles of pineapple juice because of “particle swelling” and water penetration between the cellulose chains during the heating^[5, 42]. This indicates a possible effect of the evaporation method on the increased particle size. The authors also observed that the colloidal material is usually coagulated by heating, due to the increase in the particle size. The increase in the temperature, and consequently in the thermal energy, leads to an increase in the molecular distance, which is due to a reduction in the intermolecular forces^[43]. Also, with a temperature increase, the shear stress is enhanced,

causing a rearrangement of the particles into a parallel direction and a breaking into smaller particles. These particles can flow more easily due to the decrease in the particle interactions, resulting in a viscosity.

4 Conclusions

From the experiment, it can be concluded that MVE gave great benefits in the concentration of pineapple juice. It provided a higher evaporation rate than MHE and RVE and also gave the best color in result. The concentrated behavior of pineapple juice during the three types of evaporation represents in an exponential model. According to these results, the four-parameter exponential model was the best concentrated change prediction of pineapple juice against time during MVE. The changes in Hunter parameters lightness (L^*) and yellowness (b^*) fitted well to the first-order kinetic model, while a^* , TCD and Browning index followed

(A_{420}) the zero-order kinetic model. MVE showed the best evaporation method since it provided high evaporating efficiency, reducing processing time, and retention of color quality.

In all concentrated pineapple juice, the apparent viscosities (μ_a) were decreased with the increase in temperature and shear rate. On comparing the values of μ_a of the pineapple concentrate from different concentration methods, the pineapple concentrate from MHE has higher value than those of MVE and RVE. The Duncan test, applied to the experimental results, indicates no significant difference between the μ_a of pineapple juice concentrate by MVE and by RVE, because they have the same total solid soluble and percentage of solid.

[References]

- [1] Chutintrasri B, Noomhorm A. Color degradation kinetics of pineapple puree during thermal processing. *Lebensmittel-Wissenschaft und Technologie*, 2007; 40: 300–306.
- [2] Cassano A, Drioli E, Galaverna G, Marhelli R, Di Silvestro G, Cassano P. Clarification and concentration of citrus and carrot juice by integrated membrane process. *Journal of Food Engineering*, 2003; 57: 153–163.
- [3] Jiao B. Recent advances on membrane process for the concentration. *Journal of Food Engineering*, 2003; 63: 303–324.
- [4] Konstantions B, Petrotos B, Lazarides H H. Osmotic concentration of fluid foods, *Journal of Food Engineering*, 2001; 49: 201–206.
- [5] Toribo J L, Lozano J E. Heat induced browning of clarified apple juice at high temperatures. *Journal of Food Science*, 1986; 51: 172–175.
- [6] Richardson P. *Thermal technologies in food processing : New thermal technologies.*, Woodhead Publishing Limited. 2001. pp. 178–204.
- [7] Cui Z W, Xu S Y, Sun, D W. Microwave vacuum drying kinetics of carrot slices. *Journal of Food Engineering*, 2004; 65: 157–164.
- [8] Drouzas A E, Tsami E, Saravacos G D. Microwave vacuum drying of model fruit gels. *Journal of Food Engineering*, 1999; 65: 157–164.
- [9] Fellows P: *Evaporation. Food processing technology: Principles and Practices* Ellis, Horwood, 1998. 21 p
- [10] Bondaruk J, Markowski M, Błaszczak W. Effect of drying conditions on the quality of vacuum-microwave dried potato cubes. *Journal of Food Engineering*; 2007; 81(2): 306–312.
- [11] McLoughlin C M, McMinn W A M, Magee T R A. Microwave-vacuum drying of pharmaceutical powders. *Drying Technology*, 2003; 21(9): 1719–1733.
- [12] Ramteke R S, Singh N I, Rekha M N, Eipeson W E. Methods for concentration of fruit juices-a critical evaluation. *Journal of Food Science and Technology Mysore*, 1992; 30: 391–402.
- [13] Giri S K, Prasad S. Drying kinetics and rehydration characteristics of microwave-vacuum and convective hot-air dried mushrooms. *Journal of Food Engineering*, 2007; 78: 512–521.
- [14] Akpınar E K, Bicer Y. Mathematical modeling and experimental study on thin layer drying of strawberry. *International Journal of Food Engineering*, 2006; 2(1): article 5.
- [15] Bingol G P Z, Roberts J S, Devres Y O, Balaban M O. Mathematical modeling of microwave-assisted convective heating and drying of grapes. *International Journal of Food Agricultural and Biology Engineering*, 2008; 1(2): 46–55.
- [16] Maskan M. Production of pomegranate (*Punica granatum L.*) juice concentrate by various heating methods : color degradation and kinetics. *Journal of Food Engineering*, 2006; 72: 218–224.
- [17] Assawarachan R, Noomhorm A. Effect of operating condition on the kinetic of color change of concentrated pineapple juice by microwave vacuum evaporation. *International Journal Food Agricultural and Envelopment*, 2008; 6(3&4): 47–53.
- [18] Kolawole O, Joseph C I, Funke A A. Kinetics of mass transfer, and colour change during osmotic dehydration of watermelon. *Journal of Food Engineering*, 2007; 80: 979–985.
- [19] Chen H E, Peng H Y, Chen B H. Changes of carotenoids, color and vitamin A contents during processing of carrot juice. *Journal of Agricultural and Food Chemistry*, 1995; 43(7): 1912–1918.
- [20] Ahmed J, Shivhare U S, Kaur M. Thermal color degradation kinetics of mango puree. *International Journal of Food Properties*, 2002; 5(2): 359–366.
- [21] Avila I M L B, Silva C L M. Modelling kinetics of thermal degradation of color in peach puree. *Journal of Food Process Engineering*, 1999; 39: 161–166.
- [22] Barbosa C G V, Peleg M. Flow parameters of selected commercial semi-liquid products. *Journal of Texture Studies*, 1983; 14: 213–234.

- [23] Cohen E, Birk Y, Mannheim, C H, Saguy, I S. A rapid method to monitor quality of apple juice during thermal processing. *Lebensmittel-Wissenschaft and Technologie*, 1998; 31(7-8): 612–616.
- [24] Rattanathanalerk M, Chiewchan N, Srichumpoung W, Effect of thermal processing on quality loss of pineapple juice. *Journal of Food Engineering*, 2005; 50: 259–265.
- [25] Ibarz A, Garvin A, Costa J. Rheological behaviour of sloe (*Prunus Spinosa*) fruit juices. *Journal of Food Engineering*, 1996; 27: 423–430.
- [26] Kyereme M, Hale S A, Farkas B E. Modeling the temperature effect on the flow behavior of sweet potato puree. *Journal of Food Process Engineering*, 1999; 22: 235–247.
- [27] Rao M A, Cooley H J, Orloff C, Chang K, Wijts S C. Influence of rheological properties of fluid and semi solid foods on the performance of a filler. *Journal of Food Process Engineering*, 1993; 16: 289–304.
- [28] Sengül M, Ertugay M F, Sengül M, Yüksel Y, Rheological characteristics of carob pekmez. *International Journal of Food Properties*, 2007; 10(1): 39–46.
- [29] Holdsworth S D. Processing of non-Newtonian foods. *Process Biochemistry*, 1969; 4(10): 15–21.
- [30] Ibarz A, Pagan J, Garza S. Kinetic models for color changes in pear puree during heating at relatively high temperature. *Journal of Food Engineering*, 1999; 39: 415–422.
- [31] Mizrahi S. A review of the physicochemical approach to the analysis of the structural viscosity of fluid fruit products. *Journal of Texture Studies*, 1979; 10: 67–82.
- [32] Vandresn S, Quadri M G N, de Souza J A R, Hotza D. Temperature effect on the rheological behavior of carrot juices. *Journal of Food Engineering*, 2009; 92: 269–274.
- [33] Dandamrongrak R, Young G, Mason R, Evaluation of various pre-treatments for the dehydration of banana and selection of suitable drying models. *Journal of Food Engineering*, 2002; 55: 139–146.
- [34] Doymaz I. Thin-layer drying of spinach leaves in a convective dryer. *Journal of Food Process Engineering*, 2009; 32: 112–125.
- [35] Lee J H, Kim H J. Vacuum drying kinetics of Asian white radish (*Raphanus sativus* L.) slices. *Lebensmittel-Wissenschaft and Technologie*, 2009; 42: 180–186.
- [36] McMinn W A M. Thin-layer modeling of the convective, microwave, microwave-convective and microwave-vacuum drying of lactose powder. *Journal of Food Engineering*, 2006; 72: 113–123.
- [37] Sharma G P, Verma R C, Pathare P. Mathematical modeling of infrared radiation thin layer drying of onion slices. *Journal of Food Engineering*, 2005; 71: 282–286.
- [38] Roberts J S, Kidd D R, Padilla-Zakour O. Drying kinetics of grape seeds. *Journal of Food Engineering*, 2008; 89: 460–465.
- [39] Barreiro J A, Milano M, Sandoval A J. Kinetics of color change of double concentrated tomato paste during thermal treatment. *Journal of Food Engineering*, 1997; 33: 359–371.
- [40] Garza S, Ibarz A, Pagan J, Giner J. Non-enzymatic browning in peach puree during heating. *Food Research International*, 1999; 32: 335–343.
- [41] Koca N, Burdurlu H S, Karadeniz F. Kinetics of colour in dehydrated carrots. *Journal of Food Engineering*, 2007; 78: 449–455.
- [42] Steffe J F, *Rheological Methods in Food Process Engineering* (2nd Ed). Freeman Press, East Lansing MI, 1996.
- [43] Hassan B H, Hobani A I. Flow properties of roselle (*Hibiscus sabdriffa* L.) Extract. *Journal of Food Engineering*, 1998; 35(4): 459–470.