

Precision orchard sprayer based on automatically infrared target detecting and electrostatic spraying techniques

He Xiongkui, Zeng Aijun, Liu Yajia, Song Jianli

(College of Science, China Agricultural University, Beijing 100193, China)

Abstract: There is an urgent need for new chemical application techniques and sprayers in Chinese orchard spraying. A new tractor-mounted automatic target detecting electrostatics, and air-assisted orchard sprayer was designed and developed to meet the demand of chemical pest control in orchards. This sprayer light weighted, highly efficient, reduces pesticide use and is friendly to the environment. The techniques of automatic target detecting, electrostatics, and air-assisted spraying were combined in this system. The electrostatically charged droplets are projected toward the target by the assistance of an air stream that increases the droplets penetration within canopy. Experimental results show that the new automatic target detecting orchard sprayer with an infrared sensor can save more than 50% to 75% of pesticides, improve the utilization rate (over 55%), control efficiency, and significantly reduce environmental pollution caused by the pesticide application. At the same time the key technological problems related to air-assisted low volume and electrostatic spraying were solved.

Keywords: precision spraying, orchard sprayer, automatic target plant detection, air assisted spray, electrostatic spray

DOI: 10.3965/ijabe.2011.04.01.035-040

Citation: He Xiongkui, Zeng Aijun, Liu Yajia, Song Jianli. Precision orchard sprayer based on automatically infrared target detecting and electrostatic spraying techniques. *Int J Agric & Biol Eng*, 2011; 4(1): 35–40.

1 Introduction

Chemical pest control is used 8 to 15 times per year in Chinese orchard and is one of the most important management tasks^[1]. The pedestal-mounted sprayer, the high pressure spray gun, and consecutive high volume spraying are still widely used in China. The application rate in apple orchards is almost 10 000 L/ha (1 ha=10⁴ m²). The outdated application techniques and equipments result in many problems such as high volume but low efficiency, only 15% to 20% of the pesticides deposited

on the targets, most of the pesticides lost in the surroundings, causing contamination to the operators, and serious environmental pollution^[2]. These problems lead not only to the vicious cycle of pest control, but also to other problems such as enhancing pest resistance to pesticides.

Compared with a high-pressure gun sprayer, an air-assisted orchard sprayer can reduce pesticide use by 20%, but 40% to 60% of pesticides are still lost because of the continuous spraying between the gaps in tree rows and the drift of small droplets^[3]. Air-assisted and electrostatic techniques have been combined to increase the penetration and deposit of droplets within the tree canopy and are able to reduce pesticide loss by 30%^[4]. A detection system has also been developed to discriminate between the presence and absence of trees for which spray is not needed. When the detecting devices detect the target, an automatic control system activates the spraying system to spray toward the target.

Received date: 2011-03-13 **Accepted date:** 2011-03-29

Corresponding Author: He Xiongkui, Ph.D, Professor. Research interest: modern agricultural mechanization equipment, mechatronics, and pesticide application technology and machines. Centre for Chemicals Application Technology (CCAT), College of Science, China Agricultural University. Mailing address: No. 2, Yuanmingyuan Xilu, Haidian District, Beijing 100193, China. Phone: (+86)10-62731446; Fax: (+86)10-62732830; Email: xiongkui@cau.edu.cn.

Similarly, when the automatic control system receives the signal of a gap between the trees from the “electronic eyes”, the spraying system shuts off. Infrared sensor detecting techniques have been adopted in automatic target detecting orchard sprayers to discern targets and control the spraying system automatically. These new sprayers can be commercialized easily due to the low price of infrared sensor detectors. Developed countries such as America, EU and Russia are developing automatic target detecting sprayers that utilize imaging techniques^[4-8]. Due to the high cost of imaging devices and the problems related to image processing, these sprayers remain in the experimental stage.

2 Working principle and development of sprayer

2.1 Working principle and structural composition of sprayer

The schematic diagram of the working principle of an automatic target-detecting orchard sprayer is presented in Figure 1.

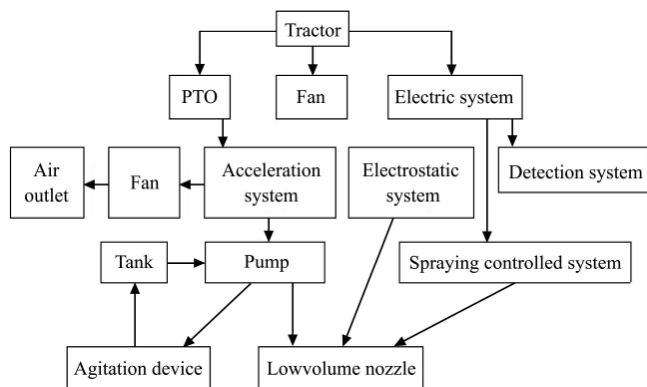
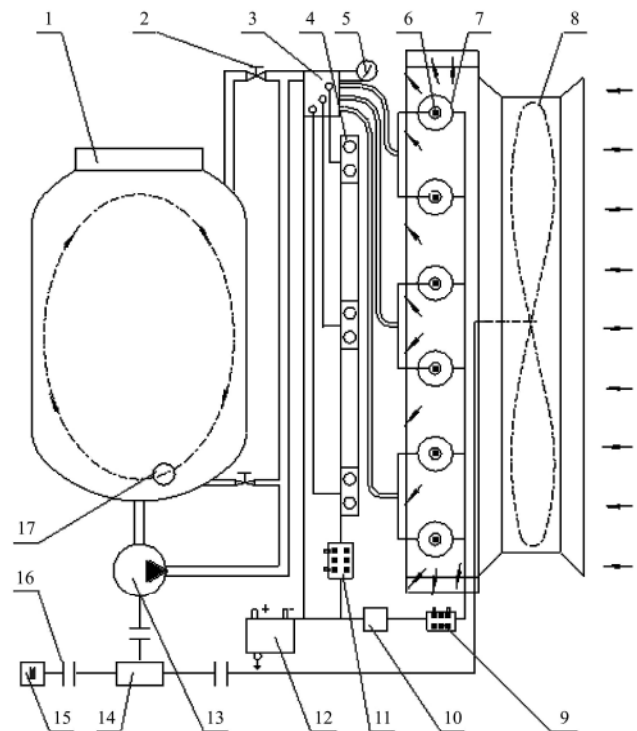

Figure 1 Schematic diagram of the working principle of automatic target-detecting orchard sprayer

In consideration of the need for flexibility and economy of operations in orchards, the new sprayer with target detecting, electrostatic, and air assisted systems was of the mounted type and was attached to the three-point hitch system of a medium or low horsepower tractor with 540 r/min PTO. The power for driving the accelerated gearbox was provided by PTO. The pump and axial fan were driven by the gear box. This sprayer was composed of a frame, tank, pump, axial fan, low

volume nozzle, electrostatic system, detection system and spraying-controlled system (Figure 2). The structure is shown as follows: Tank capacity is 300 L, the size of sprayer is 1 500 mm×1 000 mm×1 200 mm.



1. Tank 2. Pressure valve 3. Electromagnetic valve 4. Detector 5. Pressure meter 6. Nozzles 7. Electrode 8. Axial fan 9. Electrostatic controller 10. Plasma generator 11. Detector controller 12. Accumulator 13. Liquid pump 14. Gearbox 15. Power 16. Coupling of shaft 17. Agitate device

Figure 2 Structural diagram of an automatic target-detecting orchard sprayer

2.2 Spraying system

Low volume nozzles were used to decrease the time of adding pesticides and water and to improve operation efficiency. Three different hollow cone nozzles are fixed on both sides respectively. Each nozzle is matched with an electrostatic ring setting fixed on the sprayer in Figure 3. The flow rate per nozzle under 0.3 MPa pressure is, respectively, 0.39 L/min for TR-01 nozzle, 0.59 L/min for TR-015 nozzle, 0.78 L/min for TR-02 nozzle.

2.3 Axial fan and air-assisted system

Because the tree canopies are very dense, the axial fan is used to transport air for the spraying system. The large air volumes transported by the axial fan can blow leaves; thereby it can enhance droplet penetration into the tree canopy and deposition of the droplets on both sides

of the leaves. In an axial fan, air is drawn in from the center and discharged radially. The air outlet has lateral symmetry and the outlet angle can be adjusted to adapt to various tree heights. Nozzles are placed inside of the outlet to carry the droplets to crops. The diameter of the fan impeller is 630 mm and its rotational speed is 2 000 r/min (Figure 3). The wind velocity in the place of nozzles is shown in the Table 1.



Figure 3 Photo of the automatic target detecting orchard sprayer working in orchard

Table 1 Wind velocity in the position of nozzles

Nozzle	Wind Velocity/ $m \cdot s^{-1}$
1	20.1
2	22.87
3	21.07
4	21.49
5	23.06
6	23.45
7	19.89
8	24.56
9	23.12
10	25.14
11	25.13
12	25.23

2.4 Sprayer control system

An electromagnetic valve was utilized in the spray control system. Signals are received from the target detecting system, and a decision is immediately made whether to open the top, middle and bottom nozzles at the same time or to spray selectively only where targets are present in order to save pesticides.

2.5 Electrostatic system

A high voltage power supply electrostatically charges

the droplets as they exit the spray nozzle. The droplets are directed toward the target and deposit there. Electrostatic spraying allows increased spraying speed as well as improved uniformity of droplet deposition, especially on the back of leaves. The mean ratio of charge to mass increase from 0.5224 mC/kg to 1.0423 mC/kg as the voltage increases from 1 kV to 2.6 kV.

The combined effect of the air-assistance, which makes the leaves of trees vibrate, and the electrostatic charging, enhances deposition on both the upper and lower surfaces of leaves. The electrostatic nozzles and sensors are carefully matched because of the fast reaction of electromagnetic valve. The control diagram for the electrostatic system is shown in Figure 4.

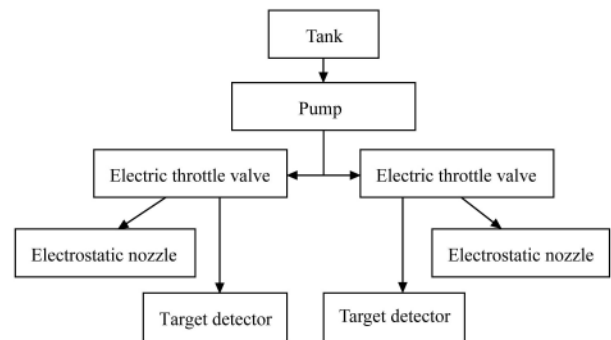

Figure 4 Diagram of target detection control for the automatic electrostatic sprayer

2.6 Target detection system

An infrared detector is utilized in the automatic target detection system. The sensors are aimed at the top, middle and bottom segments of the tree canopy in order to detect different shapes of fruit trees and provide signals to the control system.

The detection circuit is shown in Figure 5. An LM567 integrated lock mutually wreath road decode machine and its outer circle components elements constitute the lock mutually electric circuit. The triode transistor V1, infrared ray shoots transistor H1 and electric resistance R1, R9 constitute the infrared ray shoots the electric circuit. oscillatory signals from Lock mutually the electric circuit are output by the feet ⑤ of LM567, sent to the V1 to enlarge, and then drive the infrared ray shoot transistor to send out the square a signal. Integrated circuit mA741, infrared received

transistor and its outer circle components constitute the infrared receives electric circuit. The fluctuation of the signal received by the infrared ray received transistor H2 be changed into the Variety of electric resistance, then be matched by electric resistance R3 and electric capacity C3 to the feet ② of mA741, enlarged by mA741 .555

electric circuits, triode transistors V2 and related components outside constitute delay outputting electric circuit, used to control electromagnetism opened, at the time when the target being detected. Meanwhile, the green light of LED is bright; the relay switches on electricity, and the spray start.

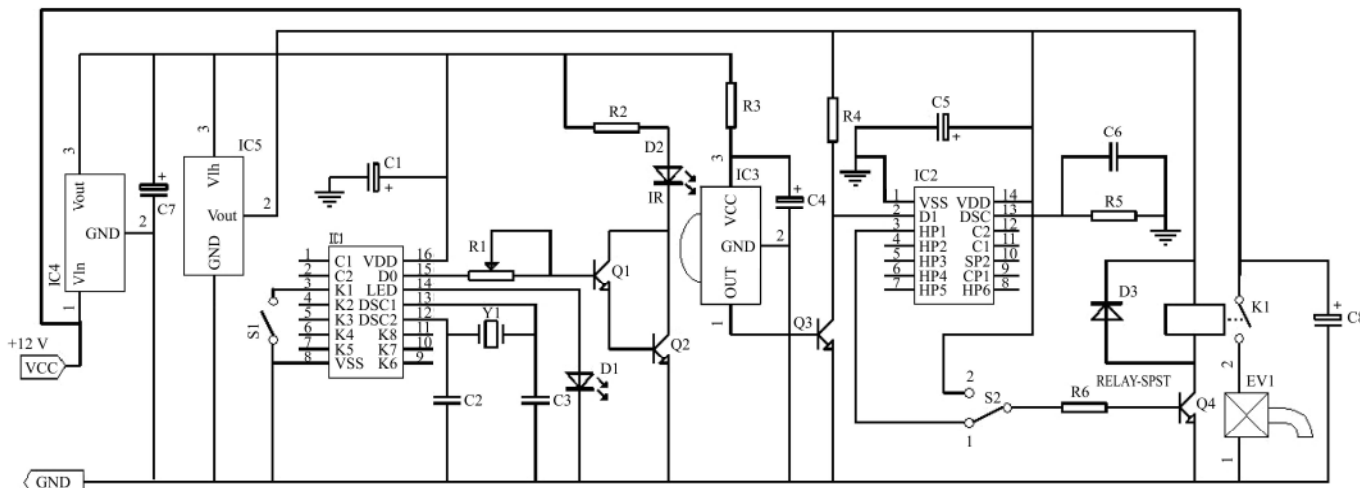

Figure 5 Schematic diagram of the electric circuit of infrared target detector

The left of Figure 5 was the launch circuit that the IC1 coder circuit was BA5104. When the controller K1 was closed by switch S1, the clock circuit of 12, 13 of coder BA5104, combined with the oscillator circuit which composed of crystal with frequency 455kHz and capacitances (C2,C3), produced a 38 kHz frequency. Then, IC1 codified the input data respectively from detector ① of C1 and detector ② of C2. Then, the output from detector 15 of DO of IC1 was multiplied by dynatron Q1, Q2 and finally was ejected through infrared ejector IR in order to adjust the infrared pulsed wave signal. Detector 14 showed the state of ejection, when IR was working, if high electric was the output, the LED1 would light, visa versa. coder 16 of VDD was contacted detector ③ of IC4 that the output was five voltage. Coder ⑧ of VSS was grounding.

The key apparatus IC3 of the incept circuit in the Figure 3 adopted an infrared incept detector of HS0038B, which had the merits of smaller volume, stronger stability of interruption from sound and light noise, no signal break, and shorter time of initialization. At the same time, the inner of HS0038B was combined with light and sound transformation circuit, magnified instruments and

adjustment circuit. When the HS0038B of IR received the reflection from targets, the infrared signal was treated by a series of precession including magnified, choose the proper frequency, and adjustment of pulses and then outputted in low electric by detector ① of IC3. After the Q3 treatment, compared with BA5204 and a decode treatment, the signal would be output in a constant high electric by the detector ③ (HP1) of IC2. While the IC3 did not received infrared signal, a low electrical would be output through HP1.

For the output circuit in the Figure 5, switch S2 was on detector 1. When the high electric form HP1 allowed the relay K1 in out circuit work out through the Q4, pesticide can be sprayed once electric-magnetic valve was thus opened. When a low electric signal was input, relay K1 switched off, electric-magnetic valve was closed and the spraying stopped at once. When switch S1 was off, the infrared circuit stopped the ejection of pulse signal, the switch S2 contact with detector 2 and a high electric signal at +3.3 V from detector was ② of IC5 was output, that allowed the relay continued to work, accordingly, the spraying can also be continued. By this method, the spraying can also be controlled under the

switch S2 arbitrarily operated by sprayers. Consider the similarity of such characters as reflection, refraction, interference, and diffraction between infrared and visible light, convex lens were allocated at the infrared ejection and received detectors. This system can redistribute and improve the infrared received as showed in Figure 3. Convex lens S1 was used to accumulate the energy of infrared and form a radiate light ray with a correct direction; Convex lens S2 was exploited to improve the absorption of energy of reflection infrared and the detection of the instrument was augmented by this optical system.

3 Experimental results

A BSF fluorometer tracer material (BSF 1F561, Germany, CHROMA-GESELLSCHAFT) was used to measure the spray deposition of droplets per area on the targets. The deposition rate was defined as deposition spray on the target to the total volume of the spray liquid. The deposition of droplets on the target is given in Tables 2 and 3. The distance between the nozzle to the target was 40–60 cm, the canopy height above the ground was 1.5–2.0 m. The data indicate that the automatic target detecting orchard sprayer with an infrared sensor can reduce pesticide dosage by 50% to 75% and improve the deposition rate on the target canopy by over 50%.

Table 2 Droplet deposition rate as affected by spraying sensor technique

	Apple trees/%	Ground/%	Drift/%
With target detecting sensor	47.6	39.8	12.6
With target detecting and electrostatic	55.4	42.3	2.4
Without target detecting and electrostatic	27.4	55.9	16.6

Table 3 Droplet deposition rate as affected by spraying electrostatic charging technique

distance /cm	charging electrical current /A		Droplets deposit increase/%
	Traditional spraying	Electrostatic spraying	
20	67.5	141.5	109.63
40	41.0	77.5	89.02
60	44.5	80.5	80.90
80	52.5	91.5	74.29

Orchard-spraying gun application research in apple production area of north China during the growth period

was carried out by Li Bingli et al. in 1991. The results showed that the droplets deposition on target was 10%-15%, which could reach 20%-25% when using air-assist application technology, but also more than 80% pesticide was lost^[1]. The experimental results (Table 2) showed that: on the basis of air-assist low volume application, infrared target detection technology was used and continuous spraying was taken place of automatic spraying which was “spraying with target and stop spraying without target”. So the deposition rate on the target was improved by more than twice; if the electrostatic application technology was included, the pesticide deposition rate was improved to 55.4%. The technical economical index indicated that this new orchard chemicals application technology has reached international advanced level.

Compared with conventional orchard air-assist application technology (Table 3), the pesticide deposition rate could be improved to 18%-40% by spraying electrostatic charging technology.

4 Conclusions

Results from the present research work were shown as follows:

1) The sprayer with target detection, electrostatic, and air-assisted systems is mounted on a 25 hp (1hp=745.7W) tractor in order to reduce the length of the sprayer to facilitate turning the tractor around. The sprayer can pass between trees separated by at least 3.0 m. The minimum discernable gap of targets by the infrared target detectors is 0.3 m. The effective detecting distance can be adjusted from 0 to 10 m depending on the row spacing of the trees.

2) The electrostatic system is able to charge the droplets to increase droplet deposition two-fold compared to spraying without the electrostatic system.

3) In order to improve the penetration of droplets in the canopy of trees, a high volume axial fan is used to transport droplets. The air volume is approximately 24 500 m³/h and the airflow velocity at the air outlet where the nozzles are fixed is more than 20 m/s.

4) The airflow produced by the axial fan increase the penetration of the electrostatically charged droplets with

in the canopy of trees and improves the efficiency and uniformity of deposition on both sides of leaves. The results of experiments demonstrated that the air assisted sprayer with infrared detecting and electrostatic systems can reduce pesticide usage more than 50% to 75% and improve the deposition rate on the target by over 50%.

[References]

- [1] Li Bingli, Wu Luoluo, He Xiongkui. Experimental study on air-assisted orchard sprayer in orchards of the north of China. *Plant Protection Machinery*, 1991; (1): 13-15.
- [2] Yuan Huizhu, He Xionkui. Herbicides deposit distribution with knapsack sprayer spraying. *Plant Protection*, 1998; 24(3): 41-42.
- [3] He Xiongkui, Zeng Aijun, He Juan. Effect of wind velocity from orchard sprayer on droplet deposit and distribution. *Trans of the CSAE*, 2002; 18(4): 75-77.
- [4] Molto E, Martin B, Gutierrez A. Pesticide loss reduction automatic spraying on globular tree. *Journal of Agricultural Engineering Research*, 2001; 78(1): 35- 41.
- [5] Rietz S, Pályi B, Ganzelmeier H, LászlóA. Performance of electronic control for field sprayers. *J Agric Engng Res*, 1997; (68): 399-40.
- [6] Tian Lei, Reid J F, Hummel J W. Development of a precision sprayer for site-specific weed management. *Trans of the ASAE*, 1999; 42(4): 893-900.
- [7] Steward B L, Tian L F, Tang L. Injection mixing system for boom less target-actived herbicide spraying. *Trans of the ASAE*, 2002; 46(4): 997-1008.
- [8] Steward B L, Tian L F, Tang L. Distance-based control system for machine vision-based selective spraying. *Trans of the ASAE*, 2002; 45(5): 1255- 1262.