

Development of a mechanical weeder and experiment on the growth, yield and quality of rice

Jinkang Jiao¹, Zhimin Wang¹, Haowen Luo², Gaolong Chen¹, Hailong Liu¹, Jinjie Guan¹,
Lian Hu¹, Ying Zang^{1*}

(1. Key Laboratory of Key Technology on Agricultural Machine and Equipment, Ministry of Education, South China Agricultural University, Guangzhou 510642, China;

2. Department of Crop Science and Technology, College of Agriculture, South China Agricultural University, Guangzhou 510642, China)

Abstract: Weed control in paddy fields is a worldwide problem and mechanical weeding will become a major weeding method in non-chemical weeding. A mechanical weeder was designed and tested to improve the efficiency of mechanical weeding and reduce the application of herbicides in this study. The weeding equipment is equipped with three sets of inter-row weeding parts which include ground-contoured-following pressing-grass float (GPF), weeding roller, and so on. The weeding principle of weeding part is that the weeding equipment enters the inter-row area with weeder moving forward, then the GPF overwhelms the weeds in the inter-row area to improve the probability that the weeding roller behind the GPF pressed the overwhelmed weeds into the soil. The effects of weeding methods on the plant height, grain yield and quality attributes were investigated in a two-seasonal field experiment. Three weeding methods were applied in the present study: no-weeding, chemical weeding and mechanical weeding. The results of the two-seasonal field experiment showed that the average weeding rates of mechanical weeders were 87.10% and 87.61% respectively. In both seasons, there was no significant difference among weeding methods on plant height at the early growth stage of rice after weeding, but weeding methods had significant effect on plant height at the late growth stage. The plant height of mechanical weeding was higher at the late growth stage. Weeding methods had significant effects on grain yield, grain number per panicle, seed-setting rate, 1000-grain weight and shoot dry matter accumulation ($p < 0.05$), however there was no remarkable effect on rice quality and other attributes ($p > 0.05$). Grain yield of mechanical weeding was significantly higher than that of no-weeding. There was no significant difference between chemical weeding and mechanical weeding. It can be concluded from the two-seasonal experiment that mechanical weeding had the same effect as chemical weeding on grain yield and rice quality.

Keywords: weeder, paddy field, mechanical weeding, grain yield, rice quality

DOI: 10.25165/j.ijabe.20221503.6978

Citation: Jiao J K, Wang Z M, Luo H W, Chen G L, Liu H L, Guan J J, et al. Development of a mechanical weeder and experiment on the growth, yield and quality of rice. *Int J Agric & Biol Eng*, 2022; 15(3): 92–99.

1 Introduction

Rice is one of the most important food crops and plays an important role in attaining food and nutritional security in the world. Analysis shows that the global demand for rice is still increasing year by year^[1,2]. Weeds in the paddy fields compete with rice for growth space, water, sunlight, and nutrients, increase the incidence of pests and diseases, and inhibit the growth of rice, which will pose a great threat to the yield and quality of rice^[3,4]. The annual loss of rice yield caused by weeds in China is about ten billion

kilograms, with an average loss rate of more than 15%, and more than 50% in severe cases^[5]. Therefore, effective weed control is very imperative to sustain rice productivity and to ensure food security in rice production.

Weeding methods in the paddy fields include manual weeding, chemical weeding such as using herbicides, mechanical weeding including weeding roller, intelligent weeding such as paddy weeding robot^[6], physical weeding such as plastic sheet mulching, biological weeding such as rice duck farming^[7], and so on. The commonly used weeding method in the world since the 1980s is chemical removal using herbicides in the paddy fields^[8,9]. However, the utilization rate of herbicides is very low, with an average utilization rate of 30%. Furthermore, herbicides cause serious environmental pollution and residues of herbicides on rice are harmful to human health. In recent years, the resistance of weeds has increased, because of the extensive and high frequency use of herbicides^[10,11]. So it is imperative to reduce the use of herbicides. On the other hand, organic rice has received more and more attention with the improvement of people's living standards^[12]. The planting area of organic rice in the world is increasing year by year. Mechanical weeding is the main weeding method for organic paddy fields.

Mechanical weeding which can maintain the stability and permeability of the soil structure, accelerate the decomposition of soil nutrients, and improve soil fertility conform to the trend of

Received date: 2021-08-11 **Accepted date:** 2022-01-10

Biographic: **Jinkang Jiao**, PhD, research interest: agricultural mechanization and automation, Email: jiaojk320@163.com; **Zhimin Wang**, MS candidate, research interest: agricultural mechanization and automation, Email: 13760670240@163.com; **Haowen Luo**, PhD, research interest: agricultural science, Email: luohaowen1995@126.com; **Gaolong Chen**, Graduate student, research interests: agricultural mechanization and automation, Email: dbalong@163.com; **Hailong Liu**, MS candidate, research interest: agricultural mechanization and automation, Email: 19120536418lhl@sina.com; **Jinjie Guan**, MS candidate, research interest: agricultural mechanization and automation, Email: 398970331@qq.com; **Lian Hu**, Professor, research interest: agricultural mechanization and automation, Email: lianhu@scau.edu.cn.

***Corresponding author: Ying Zang**, Professor, research interest: agricultural mechanization and automation. No.483 Wushan Road, Tianhe District, Guangzhou 510642, China. Tel/Fax: +86-20-38676975, Email: yingzang@scau.edu.cn.

green, high-quality, high-efficiency and sustainable development of agriculture^[13,14]. Mechanical weeding in paddy fields mostly adopts weeding methods that bury weeds in muddy water to isolate them from sunlight and air. There are also weeding methods such as spinning, tossing and cutting, drawing and so on^[15-17]. Mechanical weeding will become a major weeding method in non-chemical weeding.

Weed control in the paddy fields in European and American countries is mainly based on spraying herbicides by aircraft. The degree of mechanization of weeding is relatively higher in Japan and a variety of paddy field weeding machines have been developed such as SMW marching paddy field weeder (produced by Meishan Co., Ltd.), MSJ-4 and MSJ-6 marching paddy field weeder, riding paddy field weeder, and so on^[18]. The inter-row weeding devices are active or passive, mainly including weeding roller, rotating rake teeth, swinging comb teeth, and so on. These weeding machines are not suitable for China due to the difference in land condition and planting patterns, but they can provide some references for the research. Some paddy field weeding machines developed by Chinese researchers such as wide-width paddy field cultivator weeder and walking weeder^[19], and grid-type paddy field rows weeding device^[4], have not been widely used. The inter-row weeding devices include grid type, weeding cage type, weeding cutter teeth and so on. The wide-width paddy field cultivator weeder^[19] can weed in the intra-row by chemical weeding and inter-row by mechanical weeding at the same time and has high working efficiency. The inter-row weeding device is a weeding cutter with teeth, but it still uses a small amount of herbicide in the intra-row. The inter-row weeding device of walking weeder^[19] is an active rotary rake with teeth. The weeding rate of walking weeding is higher, but it has low efficiency and high labor-intensive. And the grid-type paddy field rows weeding device^[4] can weed in the inter-row, but weeding technology is not mature enough. Therefore, the key technology of paddy field weeding machine needs to improve urgently.

In this study, a paddy mechanical weeder that can effectively remove inter-row weeds was developed. The paddy mechanical weeder can efficiently weed in small fields such as mountains and hilly areas, and it has better flexibility and weeding efficiency. Meanwhile, it can reduce damage to rice seedling and hard bottom layer in the paddy field. And an experiment was conducted to test the weeding effect of mechanical weeder and compare the yield and quality of rice under the conditions of no-weeding, chemical weeding and mechanical weeding. This study may provide references for the development of paddy field weeding machinery.

2 Materials and methods

2.1 Mechanical weeder

A paddy mechanical weeder was designed and manufactured in the Key Laboratory of Key Technology for South Agricultural Machine and Equipment, South China Agricultural University. The paddy mechanical weeder is composed of three parts: paddy walking platform, weeding equipment remote controller and connecting mechanism (Figure 1). The mechanical weeder can walk across two rows of rice by remote control. The weeding equipment is installed behind the walking platform through the connecting mechanism which is a parallel four-bar mechanism to realize the horizontal lifting of the weeding equipment. A counterweight is required in the front of the walking platform to maintain the stability of the mechanical weeder, when the weeding equipment is installed behind the walking platform. The walking

platform walks by controlling of the remote controller and drives the weeding equipment to walk through the connecting mechanism at the same time. The mechanical weeder is controlled to aim at the rice row when weeding, then the weeding equipment is down to a suitable weeding position by controlling of remote controller, and the weeder starts walking to weeding by remote control. When turning, the weeding equipment is lifted and the mechanical weeder turns by remote control.



1. Paddy walking platform 2. Connecting mechanism 3. Weeding equipment

Figure 1 Mechanical weeder

The walking platform includes a walking mechanism, floating mechanism, steering mechanism, drive control system and frame (Figure 2). The four-wheel walking mode has wide adaptability, small turning radius, good mobility, simple control mode and small contact with the ground, which can effectively reduce the damage to rice, so the paddy impeller is used in this design. The wheel is made of pure titanium TA2 to reduce the damage to the field. The wheel spacing is determined according to the row spacing of rice, which is 600 mm. The floating mechanism is installed on the front axle of the front wheels so as to ensure that the four wheels land on the ground to reduce the impact of the uneven mud surface of the paddy field, so that the walking platform has the function of profiling floating and can improve the driving stability. The floating angle should not be greater than 11° according to the depth of paddy soil and installation site of floating mechanism. The walking platform is the front-wheel steering, and the steering mechanism which adopts the Ackerman principle and trapezoidal steering mode is driven by a linear motor. The steering motor is installed on the front of the floating mechanism. The walking platform which adopts four-wheel drive can walk along, go backward and turn in the paddy field by remote control. The four DC driving motors are respectively installed on the inner side of the four-wheel frames and the driving motor with 24 V voltage and 400 W power can ensure that the walking platform has enough power to walk in the paddy field. The walking platform is light and small, which can reduce damage to rice seedling when walking in the paddy field. In addition, the walking platform can be equipped with different agricultural machinery, and has the characteristics of stability and versatility. It belongs to the field of special agricultural robots.

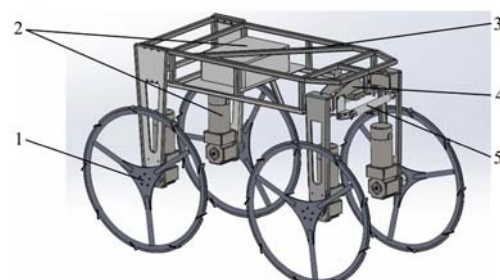

1. Walking mechanism 2. Drive control system 3. Frame 4. Floating mechanism 5. Steering mechanism

Figure 2 Walking platform

2.2 Weeding equipment

The weeding equipment is equipped with three sets of rows of weeding parts to adapt the walking platform, which can remove weeds among three rows. The distance between the weeding parts can be adjusted to adapt to different row spacing. Weeding equipment can float left and right to adapt to uneven ground.

The weeding part includes ground-contoured-following pressing-grass float (GPF), weeding roller, tension spring, holder, center shaft, connector, rack and so on. The weeding roller and holder are installed behind the GPF through the center shaft. The middle section of the holder is connected to the connector which is installed on the rack through U-bolts (Figure 3). And the tension springs are installed between GPF and holder, holder and connector, so that the weeding part and GPF have the function of ground contoured-following. The weeding principle of weeding part is that the weeding equipment enters the rice row for weeding with the walking platform advances, then the GPF overwhelms the weeds in the row to improve the probability that the weeding roller behind the GPF pressed the overwhelmed weeds into the soil. The weeding roller rotates under the action of soil resistance and presses the weeds into soil to insulate weeds from the air and sunlight to achieve the purpose of weeding. In order to press the overwhelmed weeds into the mud in time, the spacing between the weeding roller and the GPF should not be too large, about 40 mm, so as to prevent weeds from bouncing up and affect the weeding effect.

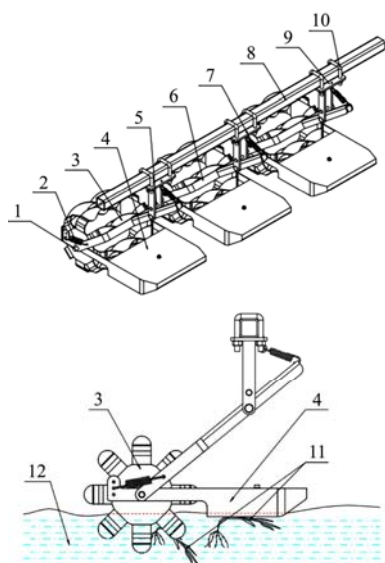

1. Center shaft 2. Tension spring 3. Weeding roller 4. Ground-contoured-following pressing-grass float 5. Axis pin 6. Holder 7. Tension spring 8. Rack 9. Connector 10. U-bolt 11. Weeds 12. Paddy field

Figure 3 Weeding equipment

2.3 Ground-contoured-following pressing-grass float

The GPF has three functions: ground contoured-following, pressing grass and pushing aside the rice seedling and it is made of 1 mm thick stainless steel, so that the GPF has the functions of ground contoured-following, pressing grass and rust protection at the same time. The front of GPF is a sealed box, which plays a role of ground contoured-following in the paddy field. And the front of sealed box is tilted upward at a certain angle, which can gradually push down the weeds; the middle and rear of sealed box is flat plate to overwhelm the weeds; The front of the side board is inclined to a certain angle inward, which can push aside the rice seedling when the weeding machine is working to prevent the weeding roller behind the GPF damaging the stem and leave of the

rice seedling (Figure 4). The width of the GPF is determined as 200 mm according to the row spacing. The length and height of the GPF are designed to be 175 mm and 55 mm respectively and the inclination angle of the front end is 45° to prevent GPF from sinking into the soil.

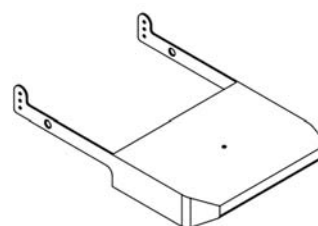
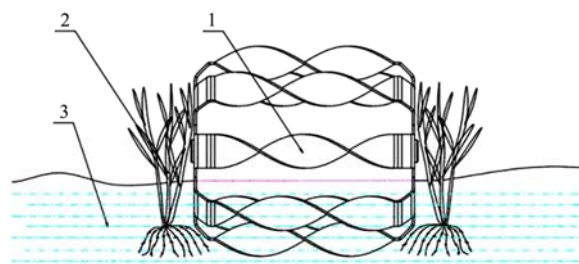

Figure 4 Ground-contoured-following pressing-grass float

2.4 Weeding roller

The weeding roller which is composed of weeding discs and weeding cutter teeth has two functions of weeding and preventing damage to rice roots. The weeding cutter teeth to crush the overwhelming weeds into soil are spiral type and evenly welded on the weeding discs, which have a better turning effect on the soil and can improve the air permeability of the soil^[19]. The rice roots are generally cone-shaped, and the included angle between most of the upper roots and the soil surface is about 30°. Also most rice roots are distributed within 100 mm of the topsoil and 180 mm of the rice center^[20]. So the ends of the cutter teeth are small and inclined at a certain angle. It can ensure to avoid the damage to the roots of rice during the weeding process of weeding roller while expanding the weeding area (Figure 5). The outer diameter and width of the weeding roller are designed to be 190 mm and 200 mm respectively, and the width and number of weeding cutter teeth are 20 mm and 8, respectively, so as to prevent the weeding roller from leaking grass, winding weeds and causing crowded mud.



1. Weeding roller 2. Rice 3. Soil

Figure 5 Weeding roller

2.5 Experimental location

Two-seasonal field experiment were conducted between July in 2020 and July in 2021 at the Experimental Research Farm, College of Agriculture, South China Agricultural University, Zengcheng, China (23°13'N, 113°81'E, and 11 m above mean sea level).

2.6 Plant materials and field experimental details

Seeds of rice cultivar, “Xiangyaxiangzhan”, a well-known and widely grown rice cultivar in South China, were provided by Teaching and Research Farm, South China Agricultural University and used in this experiment. In both seasons, seeds were soaked in water for 12 h at room temperature before sowing that can sprout more easily and fast. Then seeds were placed in an incubator at a constant temperature (38°C) in darkness for 12 h. After that shade-dried germinated seeds were sown in PVC trays with soil medium for nursery raising. And the PVC trays were placed in a puddled field and covered with a plastic sheet to protect them from any environmental disturbance. Then 15-day-old seedlings were

transplanted to the field at planting distances of 30 cm×12 cm with four to six seedlings for each hill. In the late season of 2020, the rice seedlings were transplanted on August 15 and harvested on November 20; In the early season of 2021, the rice seedlings were transplanted on April 10 and harvested on July 19. The soil of experimental field was sandy loam (pH of 5.23) with 13.56 g/kg organic matter, 0.58 g/kg total nitrogen, 49.35 mg/kg available nitrogen, 0.35 g/kg total phosphorus, 10.51 mg/kg available phosphorus, 16.24 g/kg total potassium, and 58.62 mg/kg available potassium. The soil was puddled once with a plow cultivator and then once with a rotary cultivator before transplanting. The soil was soft with a moisture content of 34% when weeding in this experiment. The soil should be soft when weeding, which has a better weeding effect.

For fertilizer, special biological organic fertilizer (Dao Feng Xiang, manufactured by Guangzhou Huayuan Agricultural Ltd, China, composed of N+P₂O₅+K₂O≥74%, active living bacteria ≥20 million/g, and organic matter≥10%), was applied at 900 kg/hm² with 60% as the basal dose and 40% at tilling. This region has a subtropical-monsoonal type of climate, and monthly mean daily precipitation, maximum and minimum ambient temperatures and hours of sunshine during the experimental cropping seasons are shown in Figure 6. The other field management in the two-seasonal field experiment was routine.

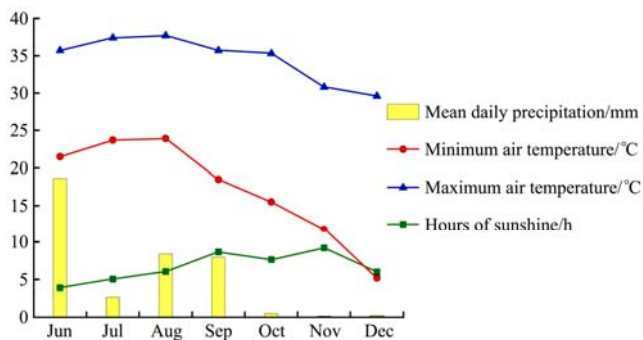

a. Late season in 2020

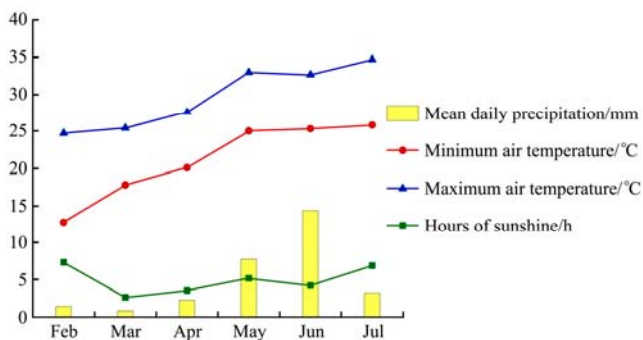

b. Early season in 2021

Figure 6 Monthly mean daily precipitation, maximum and minimum ambient temperatures and hours of sunshine during experiment

2.7 Experimental design

The following three treatments were included in each seasonal experiment: No-weeding (NW), chemical weeding (CW) and mechanical weeding (MW). NW was no any weeding treatment from sowing to harvest. CW was the application of herbicides (Pentafluoro-Cyhalofop; 750-900 mL/hm²) at 15 d after transplanting seedling of rice. MW was to weed by mechanical weeder described above at 15 d after transplanting seedling of rice. Weeds are considered to be removed when they are completely pressed into the mud, crushed or uprooted by a mechanical weeder

and lost their activity. Overwhelmed weeds were observed whether they would grow back after weeding. The weeding rate of the mechanical weeder was measured in two-seasonal field experiment, respectively. Details of the experiment are listed in Table 1.

Table 1 Details of the experiment

Details	Determination
Inter-row spacing	300 mm
Intra-row spacing	150 mm
Diameter of weeding roller	200 mm
Number of weeding roller teeth	8
Mechanical weeding width	200 mm
Mechanical weeding depth	50 mm
Weeding time	15 d after transplanting
Average height of seedling when weeding	384.8 mm
Average root depth of seedling when weeding	151.7 mm
Average height of weed when weeding	110 mm
Weed density between rows	30 plants/m ²
Weeding speed	0.5 m/s
Work efficiency	0.24 hm ² /h

In both seasons, the trial was laid out in a randomized complete block design with three treatments. Plots were 1 m (3 rice rows) wide by 10 m long, for a total of 30 plots. The experiment was carried out in the same field.

2.8 Collection of data

2.8.1 Collection of weed data

The weeding rate (WR) is an important indicator to test the weeding effect of the mechanical weeder. The number of weeds before weeding and the number of remaining weeds after weeding in the inter-row weeding area were collected in each plot respectively. The weeding rate of the mechanical weeder in each plot was calculated as

$$WR = [(N - M) / N] \times 100\% \quad (1)$$

where, WR is the inter-row weeding rate of mechanical weeder, %; N is the number of weeds before weeding in the inter-row weeding area; M is the number of remaining weeds after weeding in the inter-row weeding area.

2.8.2 Measurement of plant height

Plant height is used to compare the growth of rice among three treatments. The plant height of rice is the length from the tip of the longest leave to the bottom of plant stalk at the soil surface. The plant height of rice of each treatment was measured on the 10th day and 20th day after weeding.

2.8.3 Determination of grain yield, effective panicle number and other grain quality attributes

Rice grains were hand-harvested from three random area (1 m²) in each treatment and threshed by a threshing machine to estimate the grain yield. Harvest grains that were winnowed to remove impurities were adjusted to the standard moisture content of 13.5% and weighed to determine the grain yield of each treatment. The effective panicle number of rice grain that contains at least five plump grains was counted from three randomly selected areas (1 m²) in each treatment. The brown rice rate, milled rice rate and head milled rice rate are important manifestations of rice quality. Three groups of 80 g rice grains were collected in each treatment. Then the brown rice rate was determined by using rice huller (Jiangsu, China) and a Jingmi testing rice grader (Zhejiang, China) was used to estimate the milled rice rate and head milled rice rate. The chalkiness and chalkiness rice rate are one of the important indicators of rice appearance quality. In addition, the grain protein and amylose directly affect the taste of rice. Therefore,

the chalkiness, chalkiness rate of rice, grain protein and amylose contents were measured by SDE-A light box (Guangzhou, China) and Infratec-1241 grain analyzer (FOSS-TECATOR) respectively.

2.8.4 Estimation of grain number per panicle, seed setting rate and 1000-grain weight

Grain number per panicle, seed setting rate and 1000-grain weight are important indexes to evaluate grain yield of rice. Six representative plant hills of rice in each treatment were hand-harvested in random areas one day before all grain were harvested, dried and weighed. Then all grains per panicle in each treatment were separated manually from plant samples respectively and the grain number per panicle and seed setting rate (100%×filled grains number/total grains number) were determined by a rice digital seed testing machine (YTS-5D, Wuhan Red Star Yang Technology, China). Then, the 1000-grain weight of filled grain in each treatment was calculated and weighed.

2.8.5 Obtaining of shoot dry matter accumulation

Shoot dry matter accumulation is one of the main indicators to reflect the growth of rice. One day before the harvest, above-ground parts of six representative plant hills in each treatment were collected randomly, oven-dried to constant weight at 80°C and measured dry weights to get the weight of rice dry matter on the ground.

2.9 Statistical analysis

Experimental data of each treatment were analyzed using the standard analysis of variance procedure (SAS Institute, 2003). The relationship between treatment and the index was evaluated using correlation analyses by Statistix version 8 (Analytical software, Tallahassee, Florida, USA). The differences among means of different treatment in each indicator were separated by using least significant difference (LSD) test at 5% probability level. Graphical representation was conducted via Sigma Plot 14.0 (Systat Software Inc., California, USA).

3 Results

3.1 Effect of mechanical weeding

Major weeds found in the experimental plots were barnyardgrass, moleplant seed, wild arrowhead grass, etc. In the first seasonal field experiment, the average weeding rate of mechanical weeder in the experimental plots was 87.10%. The highest weeding rate can reach 96.97% and the lowest weeding rate was 73.81%. In the second seasonal field experiment, the average weeding rate of mechanical weeder was 87.61%, the highest weeding rate can reach 95.00% and the lowest weeding rate was 80%. A comparison before and after weeding of mechanical weeder in the same area is shown in Figure 7. In both seasons, the weeding effect of mechanical weeder was better, which can meet the weeding requirements of paddy field.

3.2 Effect of weeding methods on plant height of rice

The results of the effect of weeding method on the plant height of rice in both seasons are shown in Figure 8. The results showed that, in the two-seasonal field experiment, weeding method had no significant effect on the plant height of rice ($p>0.05$) on the 10th day after weeding. However, the plant height of MW was greater than that of NW and CW. The plant height of MW was the highest in both seasons, with an average of 580.5 mm and 611.9 mm respectively. And the plant height of NW was the lowest, with an average of 567.9 mm and 595.9 mm respectively. On the 20th day after weeding, in two-seasonal field experiment, weeding method had significant effects on the plant height of rice ($p<0.05$). Compared with NW, the plant height of CW and MW

had significant difference while it had no significant difference between CW and MW. The plant height of CW and MW was higher than that of NW and the plant height of MW was highest in the first season, with an average value of 964.8 mm, the plant height of CW was highest in the second season, with an average value of 1092.33 mm. The plant height of NW was the lowest in both seasons, the average was 918.1 mm and 981.67 mm respectively. It can be concluded from the two-seasonal field experiment that MW had the same effect as CW on the growth of rice and can promote the growth of rice to a certain degree compared with NW.

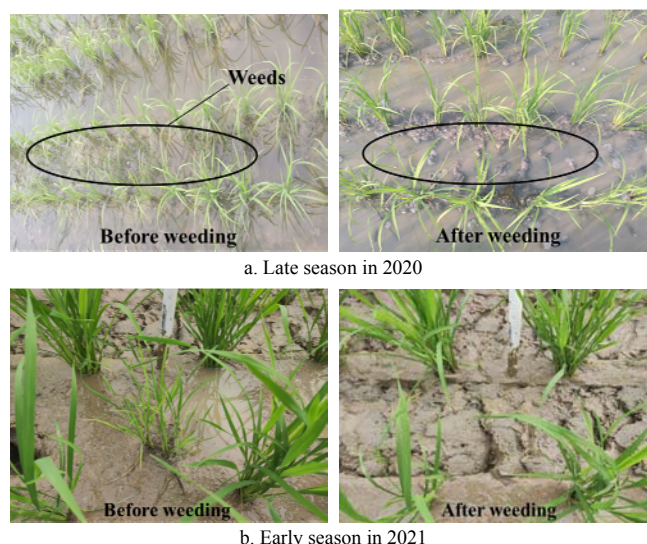
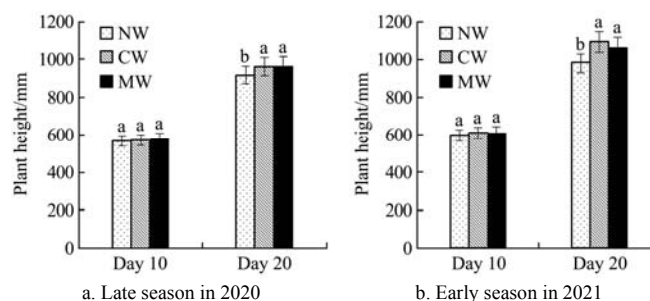

Figure 7 Comparison before and after weeding of mechanical weeder in the same area



Note: There was significant difference between different lowercase ($p<0.05$), the same below.

Figure 8 Effects of weeding methods on plant height of rice

3.3 Effects of weeding method on grain yield, effective panicle number and other grain quality attributes

As shown in Table 2, grain yield were significantly affected by weeding methods in both seasons ($p<0.05$), but weeding method had no significant effect on the other attributes of rice grains except protein ($p>0.05$). Weeding methods had significant effect on protein in the late season of 2020, but not in the early season of 2021. In both seasons, the grain yield of MW was significantly higher than that of NW, with an average value of 5.72 t/hm² and 6.42 t/hm² respectively. At the same time, there was no significant difference between CW and MW in grain yield. The grain yield of NW was the lowest, with an average value of 5.15 t/hm² and 5.4 t/hm². For protein, the grain protein content of MW was significantly lower than that of NW and CW in the late season of 2020, with an average value of 7.66%, while there was no significant difference between NW and CW. The grain protein content of NW was the highest, the average protein content was 7.95%. In the early season of 2021, there was no significant

difference in protein among weeding methods, although the protein content of MW was higher than that of CW. Compared with NW and CW, MW had no remarkable influence on effective panicle number per area, brown rice rate, milled rice rate, head milled rice rate, amylose, chalky rice rate as well as chalkiness in the

two-seasonal field experiment. It can be concluded from the two-seasonal field experiment that compared with NW and CW, MW had little effect on rice grain quality. The grain yield of MW can reach the same level as that of CW and it can increase the grain yield of rice compared with NW.

Table 2 Effects of weeding method on grain yield, effective panicle number and other grain quality attributes

Treatment	Grain yield /t·hm ⁻²	Effective panicle number per area/m ²	Brown rice rate/%	Milled rice rate/%	Head milled rice rate/%	Protein content/%	Amylose content/%	Chalky rice rate/%	Chalkiness /%
Late season in 2020									
NW	5.15 ^b	234.00 ^a	60.78 ^a	53.92 ^a	39.21 ^a	7.95 ^a	21.21 ^a	10.89 ^a	2.98 ^a
CW	5.58 ^a	242.67 ^a	60.57 ^a	54.79 ^a	39.62 ^a	7.92 ^a	20.56 ^a	13.56 ^a	4.18 ^a
MW	5.72 ^a	243.67 ^a	61.25 ^a	54.17 ^a	39.04 ^a	7.66 ^b	21.09 ^a	11.56 ^a	3.86 ^a
Early season in 2021									
NW	5.40 ^b	270.00 ^a	73.71 ^a	59.46 ^a	42.65 ^a	7.83 ^a	22.93 ^a	10.73 ^a	3.95 ^a
CW	6.38 ^a	290.00 ^a	72.93 ^a	60.18 ^a	43.47 ^a	7.79 ^a	23.63 ^a	11.43 ^a	3.02 ^a
MW	6.42 ^a	293.33 ^a	72.23 ^a	58.26 ^a	42.44 ^a	7.81 ^a	22.74 ^a	12.59 ^a	2.78 ^a

3.4 Effects of weeding method on grain number per panicle, seed setting rate, 1000-grain weight and shoot dry matter accumulation

The results of the effects of weeding method on grain number per panicle, seed setting rate, 1000-grain weight and shoot dry matter accumulation in both seasons are listed in Table 3. The results showed that, in the two-seasonal experiment, weeding methods had significant effects on grain number per panicle, 1000-grain weight and shoot dry matter accumulation ($p < 0.05$), and there was significant effect on seed setting rate in the second season, however there was no remarkable effect on seed setting rate in the first season ($p > 0.05$). For grain number per panicle in both seasons, compared with NW, MW significantly increased grain number per panicle and the average grain number per panicle were 159 and 175 respectively. There was no significant difference between MW and CW on grain number per panicle. For seed-setting rate, the seed-setting rate of MW was lower than that of NW and CW in the first season, with an average value of 75.61%, although there was no significant difference among weeding methods. And the seed-setting rate of MW was significantly higher than that of NW and CW in the second season, with an average value of 86.01%. For 1000-grain weight in both seasons, they were higher under MW than that of NW and CW, with an average value of 15.29 g and 20.04 g respectively. There was no significant difference between NW and CW on 1000-grain weight. For shoot dry matter weight, they were higher under MW than that of NW and CW, with an average value of 57.03 g/hill and 84.24 g/hill respectively. There was no significant difference between NW and CW in the first season as well as between CW and MW in the second season on shoot dry matter weight. It can be concluded from the two-seasonal field experiment that MW had

the same effect as CW on the grain number per panicle and seed setting rate of rice and MW maybe improve the grain growth and yield of rice at a certain degree according to seed-setting rate, 1000-grain weight and shoot dry matter weight.

4 Discussion

In this study, a mechanical weeder was designed and developed, and the weeding rate of weeding equipment was higher, with an average value of 87%. The weeding rate of mechanical weeder is higher than that of most weeding machines. A higher weeding rate may be due to the fact that ground-contoured-following pressing-grass floats overwhelm weeds which can increase the probability that the weeds are pushed into soil by weeding roller. Due to the good flexibility of weeds, the length of the weeds overwhelmed by the float will increase by 10% compared with that of weeds when standing upright. Therefore, the probability that weeding roller pressed onto weeds would be increased, so as to improve the weeding effect.

Figure 9 shows the weeding trajectory of weeding equipment and the state of weeds being pressed into the soil by weeding equipment. The mechanical weeder can press most of the weeds into the soil and can turn the soil between rows of rice during the weeding process, which can increase the permeability of the soil, accelerate the decomposition of soil nutrients, and improve soil fertility, this is why MW maybe increase the growth and yield of rice. It also showed that mechanical weeder worked well for weeding on soft ground and worked poorly on hard or sticky ground. In addition, Irrigation after weeding of mechanical weeder to isolate the weeds with air can further improve the weeding effect. On the other hand, the ends of the cutter teeth of weeding roller are small and inclined at a certain angle. It can ensure to avoid damage to the roots of rice during the weeding process. Figure 10 shows the weeding effects of chamfered and non-chamfered weeding rollers. The side section of chamfered weeding roller is an inclined plane, which can avoid damaging the rice roots. However, the side section of non-chamfered weeding roller is straight and deep, which will cause direct damage to the rice roots. Therefore, the chamfered weeding roller may be conducive to the growth of rice. It still needs to be further verified by experiments about the effect of weeding roller on roots and growth of rice.

Compared with other weeding machines, the mechanical weeder is suitable for small-area paddy fields in hills and mountains, with high work efficiency and flexible operation. And

Table 3 Effects of weeding method on grain number per panicle, seed setting rate, 1000-grain weight and shoot dry matter accumulation

Treatment	Grain number per panicle	Seed-setting rate /%	1000-grain weight/g	shoot dry matter weight/g·hill ⁻¹
Late season in 2020				
NW	137 ^b	75.70 ^a	13.64 ^b	51.37 ^b
CW	156 ^a	77.45 ^a	13.08 ^b	51.58 ^b
MW	159 ^a	75.61 ^a	15.09 ^a	57.03 ^a
Early season in 2021				
NW	146 ^b	84.00 ^a	18.95 ^b	50.82 ^b
CW	188 ^a	79.05 ^b	18.74 ^b	74.78 ^a
MW	175 ^a	86.01 ^a	20.04 ^a	84.24 ^a

the mechanical weeder is light and small, which can reduce damage to rice seedling when weeding in the paddy field. The weeding equipment can effectively remove weeds, turn over the soil and improve the air permeability of the soil. Meanwhile, the chamfered weeding roller can avoid damage to the roots of rice and maybe conducive to the growth of rice.



Figure 9 Weeding trajectory of weeding equipment and the state of weeds being pressed into the soil by weeding equipment



Figure 10 Weeding effects of chamfered and non-chamfered weeding roller

Two-seasonal field experiment results showed that there was no remarkable difference among weeding methods on plant height at the early growth stage of rice after weeding, but weeding methods had significant effect on plant height at the late growth stage. The plant height of CW and MW was larger than that of NW. This result was the same as that of Sori et al.^[6], and Ali et al.^[13]. The mainly reason was that CW and MW decrease weed-rice competition during the critical rice-growth after weeding and thereby it can provide better rice-growing environment and nutrition to rice. In both seasons, the yield of MW, which had no significant difference from that of CW, was highest in all of the weeding methods and it was lowest under NW. The 1000-grain weight and shoot dry matter accumulation were significantly higher than those of NW and CW. These findings agreed with those reported by Sori et al.^[6], Rajkhowa et al.^[8] and Ali et al.^[13], which indicated that MW enhanced the growth of rice. Compared with NW, the main reason why the yield of MW was higher maybe that fewer weeds compete with rice for sunlight, growth space, air, water and nutrients. But the yield of MW was higher than that of CW reported by Qi et al.^[19]. This result was different from this paper. The main reason was that 3GY-1920 wide-swath type weeding-cultivating machine designed by Qi et al.^[19] can weed in the intra-row by chemical weeding and inter-row by mechanical weeding at the same time, but mechanical weeder in this study only can weed by mechanical weeding in the inter-row. Meanwhile, one seasonal experiment was only carried out by Qi et al.^[19] and the significance of the experimental result reported was not analyzed. Compared with CW, some indicators of MW were higher, probably because some components of herbicides slightly

inhibit the growth of rice. There were no remarkable differences among weeding methods on grain quality attributes of rice, which illustrate that MW had little obvious effect on rice quality. There are no reports about the effect of weeding methods on rice quality at present. Some large-scale weeding machines were designed and developed by researchers. Compared with the large-scale weeding machines, mechanical weeder can effectively reduce the crushing damage to the hardcore of the field and crops, it can keep higher weeding efficiency at the same time. In this study, weeding equipment can expand the weeding area between rows and reduce the damage to rice roots.

Anyway, weeds in paddy fields can cause the serious losses of rice yield; Long term use of herbicides can cause environmental pollution, harm human health and enhance weeds resistance; MW by mechanical weeder designed in this study can reach the same level as CW about growth and yield of rice and cannot decrease the rice quality. In addition, mechanical weeder will reduce the environmental pollution caused by herbicides. Therefore, it is feasible to use mechanical weeder for weeding in paddy field or organic rice cultivation.

5 Conclusions

A mechanical weeder was designed and tested in this study, the average weeding rates of mechanical weeder in the two-seasonal field experiment were 87.10% and 87.61% respectively. The effects of weeding methods on the plant height, grain yield and quality attributes were investigated in the two-seasonal field experiment. The results from the two-seasonal field experiment showed that there was no significant difference among weeding methods on plant height at the early growth stage of rice after weeding. Weeding methods had a significant effect on plant height at the late growth stage, but it had no significant difference between chemical weeding and mechanical weeding. The plant height of mechanical weeding was higher than that of no-weeding at the late growth stage. Weeding methods had significant effects on grain yield, grain number per panicle, seed-setting rate, 1000-grain weight and shoot dry matter accumulation in both seasons ($p < 0.05$), however there was no remarkable effect on rice quality and other attributes ($p > 0.05$). Grain yield of mechanical weeding was significantly higher than that of no-weeding in both seasons, with an average value of 5.72 t/hm² and 6.42 t/hm². There was no significant difference between chemical weeding and mechanical weeding on grain yield. The grain number per panicle of chemical weeding and mechanical weeding was higher than that of no-weeding. The 1000-grain weight and shoot dry matter accumulation of mechanical weeding were significantly higher than those of no-weeding and chemical weeding. The results indicated that the grain yield of mechanical weeding was similar to that of chemical weeding. The mechanical weeding by mechanical weeder can improve the growth of rice and had little obvious effect on rice quality. In conclusion, the proposed mechanical weeder can be used for weeding in the paddy field, and it can reduce the application of herbicides and the subsequent environmental pollution.

Acknowledgements

This work was financially supported by the Key-Area Research and Development Program of Guangdong Province (Grant No. 2019B020224001). The authors also acknowledge the anonymous reviewers for their critical comments and suggestions for improving the manuscript.

[References]

- [1] Duary B, Mishra M M, Dash R, Teja K C. Weed management in lowland rice. *Indian Journal of Weed Science*, 2015; 47(3): 224–232.
- [2] Zhu D F, Wang Y L. Analysis of characteristics of temporal and spatial variation of rice production in the world. *China Rice*, 2021; 27(1): 7–8. (in Chinese)
- [3] Zoschke A. Toward reduced herbicide rates and adapted weed management. *Weed Technol*, 1994; 8: 376–386.
- [4] Liu Y J, Wang J W, Tao G X, Zhang C F. Kinematics analysis and experimental study on grid inter-row weed control device for paddy field. *Journal of Agricultural Mechanization Research*, 2015; 5: 155–158.
- [5] Dong L Y, Gao Y, Fang J P, Chen G Q. Research progress on the herbicide-resistance of weeds in rice fields in China. *Plant Protection*, 2018; 44(5): 69–76. (in Chinese)
- [6] Sori H, Inoue H, Hatta H, Ando Y. Effect for a paddy weeding robot in wet rice culture. *Journal of Robotics and Mechatronics*, 2018; 30(2): 198–205.
- [7] Wang Z, Xi Y G. The development of organic rice at home and abroad and the research progress of organic rice quality. *Acta Agriculturae Shanghai*, 2014; 30(1): 103–107. (in Chinese)
- [8] Rajkhowa D J, Deka N C, Borah N, Barua I C. Effect of herbicides with or without paddy weeder on weeds in transplanted summer rice (*Oryza sativa*). *India Journal of Agronomy*, 2007; 52(2): 107–110.
- [9] Mahilang K, Choudhary S, Victor V M, Sihag N, Sonboier K. Design and development of power operated rotary weeder for rice. *Current Journal of Applied Science and Technology*, 2017; 24(5): 1–7.
- [10] Liu X L, Sun T, Fu S J, Zhong G H. Herbicide application and weeds resistance in rice field in China. *Journal of Northwest A&F University (Nat. Sci. Ed.)*, 2015; 43(7): 115–126. (in Chinese)
- [11] Vencill W K, Nichols R L, Webster T M, Soteris J K, Mallory-Smith C, Burgos N R, et al. Herbicide resistance: Toward an understanding of resistance development and the impact of herbicide-resistant crops. *Weed Sci*, 2012; 60(S1): 2–30.
- [12] Saha S, Pandey A K, Gopinath K A, Bhattacharaya R, Kundu S, Gupta H S. Nutritional quality of organic rice grown on organic composts. *Agron Sustain Dev*, 2007; 27(3): 223–229.
- [13] Ali M, Bir S H, Rahman H, Ayesha S K, Hoque A, Harun-Ar-Rashid, Islam R, et al. Effect of crop establishment and weed control method on productivity of transplanted *aman* rice. *Weed & Turfgrass Science*, 2018; 7(2): 120–129.
- [14] Shrivastava A, Vermab A, Gangulya S K. Design of compound die for production of cutting blades for nonactive rotary paddy weeder. *Materials and Manufacturing Processed*, 2015; 30: 1412–1416.
- [15] Rodenburg J, Saito K, Irakiza R, Makokha D W, Onyuka E A, Senthikumar K. Labor-saving weed technologies for lowland rice farmers in sub-Saharan Africa. *Weed Technol*, 2015; 29: 751–757.
- [16] Shoji K, Itoh K, Kawahara F, Yoshida Y, Yamamoto Y, Sudo K. Micro-elevations in paddy fields affect the efficacy of mechanical weeding: Evaluation of weeding machines to control *Monochoria vaginalis* in herbicide-free farming. *Weed Biol. Manag.*, 2013; 13(2): 45–52.
- [17] Tian L, Cao C M, Qin K, Fang L F, Ge J. Design and test of post-seat weeding machine for paddy. *Int J Agric & Biol Eng*, 2021; 14(3): 112–122.
- [18] Gongotchame S, Dieng I, Ahouanton K, Johnson J M, Alognon A D, Tanaka A, et al. Participatory evaluation of mechanical weeders in lowland rice production systems in Benin. *Crop Prot*, 2014; 61: 32–37.
- [19] Qi L, Zhao L L, Ma X, Cui H W, Zheng W H, Lu Y L. Design and test of 3GY-1920 wide-swath type weeding-cultivating machine for paddy. *Transactions of the CSAE*, 2017; 33(8): 47–55. (in Chinese)
- [20] Yang L, Peng J, Shao P. Modeling and visualization of rice roots based on morphological parameters. *IEEE Access*, 2020; 8: 23407–23416.