

# Potato seed-metering monitoring and improved miss-seeding catching-up compensation control system using spatial capacitance sensor

Guanping Wang, Xiaoping Yang, Wei Sun<sup>\*</sup>, Yan Liu, Chengjiang Wang,  
Hua Zhang, Xiaolong Liu, Bin Feng, Hongling Li

(Mechanical and Electrical Engineering College, Gansu Agricultural University, Lanzhou, Gansu 730070, China)

**Abstract:** The congenital yield reduction caused by miss-seeding in spoon-type seed-metering device of small and medium-sized potato planter is huge. Based on the physical mechanism of different measured capacitance values between two fixed capacitor plates with different media, a miss-seeding detection scheme based on a spatial capacitance sensor is proposed first. A simple and efficient spatial capacitance sensor that can obtain as large capacitance measurement value as possible is designed, and a dual CPU coordinated seed-monitoring and compensation control system architecture is adopted. AD7745 is selected for the capacitance measure of the spatial capacitance sensor, and the code of grating encoder is also recorded at the same time. Thereby, when each potato spoon passing through the space surrounded by the capacitor plates, the maximum net capacitance fluctuation and its corresponding position can be acquired. A suitable threshold can distinguish between normal-seeding and miss-seeding effectively. Moreover, it should be emphasized that, this monitoring system only requires one monitoring point. Then, based on obtained information, an improved miss-seeding catching-up compensation plan is put forward. By utilizing the powerful memory capability of the CPU, this system does not need to complete compensation immediately after the miss-seeding identification. Instead, the miss-seeding information and the location of the accident can be just marked in advance, and only when the opportunity arrives, can the miss-seeding catching-up compensation be truly executed. In this way, the position of the seed-monitoring points can be free from restriction, and the control strategy can therefore be significantly simplified. The soil tank test data showed that, the identification accuracy of the miss-seeding detection system was not less than 94%. When the seed-metering chain speeds are 0.2, 0.3, and 0.4 m/s, the average success rates of the miss-seeding compensation system are 94.32%, 83.65%, and 75.00%, respectively. The final miss-seeding rate can be below 3%, and the average deviation compensation rate was not higher than 30%, the miss-seeding was suppressed significantly. This system is a beneficial try in the non-photoelectric detection field and low complexity miss-seeding compensation for potato seeding.

**Keywords:** potato planter, seed-metering monitoring, miss-seeding, spatial capacitance sensor, maximum net capacitance fluctuation, improved catching-up compensation

**DOI:** [10.25165/ijabe.20241704.8475](https://doi.org/10.25165/ijabe.20241704.8475)

**Citation:** Wang G P, Yang X P, Sun W, Liu Y, Wang C J, Zhang H, et al. Potato seed-metering monitoring and improved miss-seeding catching-up compensation control system using spatial capacitance sensor. *Int J Agric & Biol Eng*, 2024; 17(4): 255–264.

## 1 Introduction

Potato is the fourth largest crop in the world and is crucial for global food security. According to the data from Huajing Industry Research Report, the global potato planting area in 2020 was

19.59 million hm<sup>2</sup>. Among them, the potato area in China exceeds 5 million hm<sup>2</sup>, with an equivalent grain yield of 18.312 Mt<sup>[1]</sup>. The suitable potato planting places in China are mostly arid and semi-arid mountainous areas, and large-scale agricultural machinery is not popular. Correspondingly, small and medium-sized spoon-type potato planters are widely used due to their simplicity and efficiency<sup>[2,3]</sup>. However, because of the pursuit of simple structure and cost control, its reliability is relatively insufficient, often resulting in miss-seeding due to the missed selection of potato seed by the seed spoon, which will lead to an annual congenital reduction of 5%-8%<sup>[4-6]</sup>. This is indeed an alarming number, and in some populous developing countries, it may even threaten basic livelihoods. At present, the main approach used to solve this issue is manual replanting, which is labor-intensive and inefficient<sup>[7]</sup>. Therefore, the correct solution is to use sensors for miss-seeding detection and adopt automatic devices for compensation<sup>[8]</sup>. This will not only greatly reduce the demand for labor, but also meet the requirements of the Precision Agriculture.

From a global perspective, the pursuit of Precision Agriculture has a long history. Since the 1940s, European and American countries have been the first to develop precision sowing machines for traditional bulk crops such as maize and soybeans. Nowadays,

**Received date:** 2023-08-10 **Accepted date:** 2024-06-13

**Biographies:** **Guanping Wang**, PhD, Professor, research interest: agricultural electrification and its automation, Email: [wangguanping@gsau.edu.cn](mailto:wangguanping@gsau.edu.cn); **Xiaoping Yang**, MA Eng, Professor, research interest: agricultural mechanization; engineering, Email: [yangxp@gsau.edu.cn](mailto:yangxp@gsau.edu.cn); **Yan Liu**, MA Eng, Lecturer, research interest: agricultural electrification and its automation, Email: [751741004@qq.com](mailto:751741004@qq.com); **Chengjiang Wang**, MA Eng, research interest: agricultural electrification and its automation, Email: [690123023@qq.com](mailto:690123023@qq.com); **Hua Zhang**, PhD candidate, Senior Experimenter, research interest: agricultural mechanization engineering, Email: [342119021@qq.com](mailto:342119021@qq.com); **Xiaolong Liu**, PhD candidate, Senior Experimenter, research interest: agricultural mechanization engineering, Email: [liuxiaol@gsau.edu.cn](mailto:liuxiaol@gsau.edu.cn); **Bin Feng**, PhD, Associate Professor, research interest: agricultural mechanization engineering, Email: [470236645@qq.com](mailto:470236645@qq.com); **Hongling Li**, MA Eng, research interest: agricultural electrification and its automation, Email: [lihongling@gsau.edu.cn](mailto:lihongling@gsau.edu.cn).

**\*Corresponding author:** **Wei Sun**, PhD, Professor, Assistant Dean, research interest: agricultural mechanization engineering. Mechanical and Electrical Engineering College, Gansu Agricultural University, Lanzhou, 730070, China. Tel: +86 13919449740, E-mail: [sunw@gsau.edu.cn](mailto:sunw@gsau.edu.cn).

the new technologies which can adapt to natural conditions and production requirements in different regions is developed continuously<sup>[9,10]</sup>. In terms of potato planting, large machinery is commonly used in European and American countries, with large seed boxes, high seed filling surfaces, and larger seed block volumes (especially for whole potato planting). The widespread use of measures, such as optimized iteration and simple monitoring in the design of seed-metering systems, averagely, has resulted in the sum of miss-seeding and multi-seeding rate being less than 5%<sup>[11]</sup>. In addition, its small population size and vast land area make the impact of this kind of congenital production reduction almost negligible. However, the situation in the majority of developing economies, such as China, will be completely different.

Therefore, objectively speaking, the region with the most urgent demand for precision potato planting should be a populous developing country like China.

China's research in this field began after 2010. Zhang et al.<sup>[12]</sup> first proposed an automatic seed-metering and compensation system for potato seeding, consisting of photodiodes, microcontrollers, and stepper motors as the core components. This system marks the beginning of the application of infrared photoelectric detection methods in potato seed-metering monitoring. Although its detection scheme is rough and low reliable, and the compensation scheme driven by a stepper motor has slow speed and poor accuracy, it is a foundational literature in this field and has a profound impact on subsequent research. On this basis, Liu et al.<sup>[13]</sup> and Sun et al.<sup>[14]</sup> proposed a scheme for infrared photoelectric detection, using a microcontroller triggered by a position sensor, to determine whether a miss-seeding has occurred. They also provided detailed hardware implementation case and software programming structure, which improved the reliability of seed-metering detection significantly. In terms of its seed-metering compensation scheme, whether it is the crank connecting rod strike<sup>[13]</sup> or the electromagnet impact discharge<sup>[14]</sup>, they were all characterized by simple, direct, and quick. However, the premise is that the potato seed to be compensated can exist reliably in the designated area in advance, at the same time, its movement channel need to be unblocked. Therefore, its application conditions are relatively harsh. Inspired by literature<sup>[13]</sup>, Wang et al.<sup>[15]</sup> proposed a scheme of infrared miss-seeding detection triggered by a reed relay and miss-seeding compensation system based on nest eye groove wheel seed-metering device. The accuracy of the miss-seeding detection system is equivalent to that in Liu et al.<sup>[13]</sup> and Sun et al.<sup>[14]</sup>, but the compensation system structure is simplified, with shorter replanting travel and faster action. Nevertheless, the incident of potato seed being pinched by nest eye groove wheel happened frequently. Therefore, from a technical perspective, schemes that result in complex structures and difficulty in precise control of potato seed to be compensated landing points are not popular, while programs that are simple, rapid, and zero landing offset, but must be implemented in certain cavities still have poor practicality. This has attracted attention to the choice of using the same planting channel for normal-seeding and miss-seeding compensation. Based on this belief, between 2018 and 2021, Dr. Wang's team from Gansu Agricultural University declared a new plan named integrated seeding and compensating potato planter based on one-way clutch<sup>[16,17]</sup>, their prototype tests have shown that, the feasibility of this scheme is significantly superior to the existing systems, and it has the value of further optimization and promotion.

Due to the varying degrees of impact of high dust environments and sunlight irradiation on infrared photoelectric detection, in recent

years, non-photoelectric detection techniques for potato seed-metering monitoring have received increasing attention. For example, as early as 2009-2010, Zhou et al.<sup>[18]</sup> were able to identify faults reliably such as interruption and blockage in wheat seeding based on the changes in capacitance sensor signals. Later, they further improved the plan and applied this idea to maize seed-monitoring<sup>[19]</sup>. Encouraged by these exciting achievements, for the first time, Niu et al.<sup>[20]</sup> proposed a new scheme for capacitive sensing miss-seeding detection based on Programmable Logic Controller (PLC) in potato planting. This study used a peak-seeking algorithm to process the captured capacitance pulse signal, obtained the peak capacitance, and compare it with the zero point of the base capacitance to determine whether there was miss-seeding. This detection method has better dust and vibration resistance effects, and the way to obtain capacitance values was also quite simple, representing a new trend in this field. Zhang et al.<sup>[21]</sup>, on the other hand, paid more attention to the influence of external environmental parameters such as temperature and humidity on capacitance measurement values, laying the foundation for further research.

In summary, based on the integrated concept of non-photoelectric monitoring plus miss-seeding compensation, this study proposes a joint scheme of capacitive sensing miss-seeding detection and improved catching-up compensation. The innovation of this study mainly focuses on the identification of seed-metering information based on the maximum net capacitance fluctuation and the implementation of improved catching-up compensation based on position memory information.

## 2 System scheme

### 2.1 Structure of a new potato planter

The research content and system described in this study are important components of a new integrated seeding and compensating potato planter, therefore, the system composition of the machine needs to be introduced briefly first.

The structural diagram of the new potato planter is shown in [Figure 1](#), it is composed of an improved one row potato planter, a spatial capacitance sensor, a miss-seeding compensation system based on one-way clutches, and a system controller. The composition and interrelationships of the spatial capacitance sensor, the miss-seeding compensation system based on one-way clutches, and the system controller are the focus of this article.

As shown in [Figure 1](#), the seed-monitoring device and miss-seeding compensation system are installed on the improved one row potato planter. Among them, the spatial capacitance sensor is installed above the seed box to assist in the sowing status monitoring and the potato spoon position determining; the absolute value grating encoder is installed on the one side of seed-metering chain wheel axle I, and is responsible for the real-time speed detecting of the seed-metering chain and accurate position obtaining of the target potato spoon; the motor (stepper) is connected to the seed-metering chain wheel axle II through a compensating one-way clutch, responsible for providing power during the improved catching-up compensation. However, the system controller is installed on the side of seed box. As a core component, the system controller can only make seeding status judgments and other information updates based on obtaining the sufficient spatial capacitance sensor measurement values. On this basis, only after further obtaining the seed-metering chain speed and the target potato spoon position information, can the miss-seeding compensation command be issued.

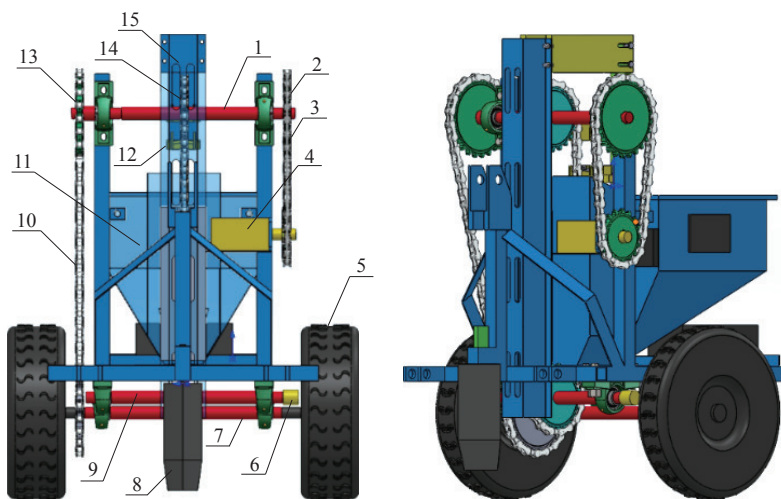

1.Seed-metering chain wheel axle II 2.Compensating one-way clutch 3.Power transmission chain for miss-seeding compensation 4.Motor 5.Land wheel 6.Absolute value grating encoder 7.Land wheel axle 8.Trencher 9. Seed-metering chain wheel axle I 10. Land wheel power transmission chain 11.Seed box 12. Spatial capacitance sensor 13. Main power transmission one-way clutch 14. Seed-metering chain 15. Seed-metering groove.

Figure 1 Structure of the new integrated seeding and compensating potato planter

From Figure 1 and the composition structure as well as internal logic of the new potato planter, it is known that, the system controller is the key to coordinating the two major tasks of seed-monitoring and miss-seeding compensation, as a result, it is the center for the operation of the entire machine. Due to the related data fast collection speed, large data volume, and high real-time requirements of spatial capacitance sensor and absolute value grating encoder, a dual CPU scheme is adopted for this controller and its functional block diagram is shown in Figure 2. In this

system, CPU1 completes capacitance measured value reading, grating encoder reading, information storage, miss-seeding judgment, and communication with CPU2. Its task feature is strong real-time performance. CPU2, on the other hand, focuses on results display, human-machine interface, data reception for communication with CPU1, potato spoon position information refreshing, seed-metering chain speed calculation, basic parameter update, miss-seeding compensation control and sound-light alarming generating.

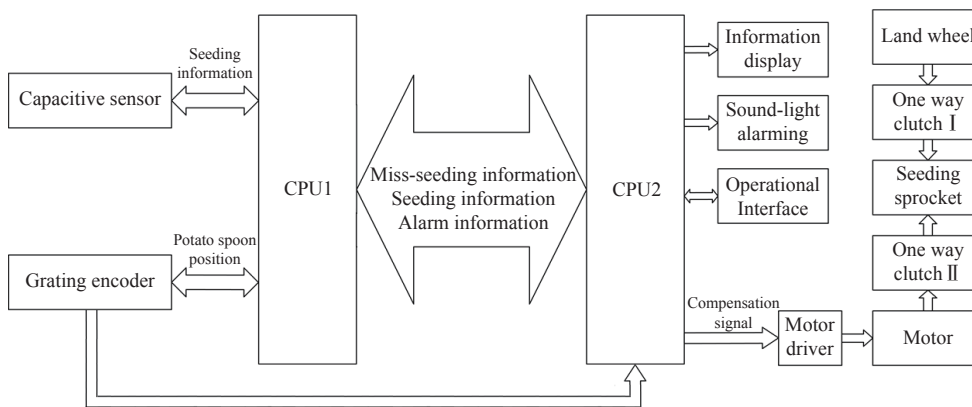

Figure 2 Schematic diagram of seed-monitoring and control system

2.2 Working principle

2.2.1 Theoretical basis of miss-seeding detection

Based on practical needs and the standard requirements for cutting potato seeds, the spatial capacitance sensor designed in this study is shown in Figure 3. Its capacitance can be calculated by Equation (1).

$$C = \frac{\epsilon_r \epsilon_0 S}{d} \tag{1}$$

where,  $C$  is the capacitance value between plates, F;  $\epsilon_r$  is the relative dielectric constant of the medium between plates;  $\epsilon_0$  is the vacuum dielectric constant, F/m;  $S$  is the effective projected area of the axial plane between the plates,  $m^2$ ;  $d$  is the distance between two plates of the space capacitance sensor, m.

Therefore, according to Equation (1), the measured capacitance will change synchronously with the dielectric between the capacitor

plates. This study is based on the fact that the measured capacitance under the empty spoon is significantly smaller than the normal condition. Consequently, the core of potato seed-metering state identification based on capacitance sensing detection lies in the change of relative dielectric constant between capacitor plates,

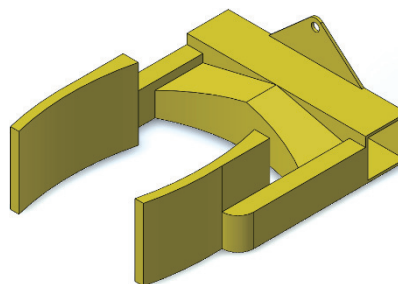

Figure 3 Structure of the spatial capacitance sensor

which can be expressed as:

$$\begin{cases} \epsilon_{r1} = \epsilon_{r0} \frac{V_{01}}{V} + \epsilon_{rc} \frac{V_c}{V} \\ \epsilon_{r2} = \epsilon_{r0} \frac{V_{02}}{V} + \epsilon_{rc} \frac{V_c}{V} + \epsilon_{rs} \frac{V_s}{V} \\ \epsilon_{r3} = \epsilon_{r0} \frac{V_{03}}{V} + \epsilon_{rc} \frac{V_c}{V} + \epsilon_{rs} \frac{V_s}{V} + \epsilon_{rp} \frac{V_p}{V} \end{cases} \quad (2)$$

where, for the seed-metering chain, potato spoon, and cutting potato seed,  $\epsilon_{rc}$ ,  $\epsilon_{rs}$ , and  $\epsilon_{rp}$  are the relative dielectric constants, respectively;  $V_c$ ,  $V_s$ , and  $V_p$  are the volume occupied by them individually in the volume  $V$  surrounded by the spatial capacitance sensor plates,  $m^3$ ;  $\epsilon_{r0}$  is the relative dielectric constant of air.  $V_{01}$ ,  $V_{02}$ , and  $V_{03}$  are the air volume under the no-spoon, no-load, and loaded states severally,  $m^3$ ; while the corresponding  $\epsilon_{r1}$ ,  $\epsilon_{r2}$ , and  $\epsilon_{r3}$  represent the equivalent relative dielectric constants of the three states mentioned above, and their corresponding capacitance value can be read as:

$$\begin{cases} C_1 = \frac{\epsilon_{r1} \epsilon_0 S}{d} \\ C_2 = \frac{\epsilon_{r2} \epsilon_0 S}{d} \\ C_3 = \frac{\epsilon_{r3} \epsilon_0 S}{d} \end{cases} \quad (3)$$

The magnitude of the change in spatial capacitance sensor (i.e. the maximum net capacitance fluctuation)  $\Delta C_1$  and  $\Delta C_2$ , caused by the equivalent relative dielectric constants change under no-load and loaded states individually are:

$$\begin{cases} \Delta C_1 = C_{2\text{-max}} - C_1 \\ \Delta C_2 = C_{3\text{-max}} - C_1 \end{cases} \quad (4)$$

where,  $C_1$  is the average value of spatial capacitance sensor over a long period of time under the no-spoon state, which will be continuously updated. In this state, only the seed-metering chain passes through the space under the jurisdiction of the spatial capacitance sensor plates.  $C_{2\text{-max}}$  and  $C_{3\text{-max}}$  are the maximum values of the spatial capacitance sensor measurement during the process of

a potato spoon passing through the electrode plate space under no-load and loaded states, respectively. However, this requires a high capacitance sampling rate objectively.

### 2.2.2 Improved miss-seeding catching-up compensation work rules

The key technologies for potato miss-seeding compensation include miss-seeding judgment, potato spoon positioning, seed-metering chain speed calculation and precise motor speed control. After the miss-seeding based on spatial capacitance sensor is discovered, there is no need to compensate immediately. Only when the corresponding potato spoon reaches the appropriate accelerate point and the compensating conditions are met, can the improved catching-up compensation be executed. The specific execution process of this scheme can be shown in Figure 4. Here, only take the 0<sup>#</sup> potato spoon as an example, according to Figure 4, assuming that it is detected a miss-seeding event, its status flag  $S(0)$  will immediately be changed from 1 to 0, and the code of the grating encoder at that time will be recorded. Under normal conditions (i.e.  $S(1)=1$ ) in adjacent subsequent potato spoon (i.e. 1<sup>#</sup> potato spoon), the compensation motor operating time  $t_a$  can be obtained based on  $v_L$  within a sampling interval before the 0<sup>#</sup> potato spoon reach the accelerate point P. When the 0<sup>#</sup> potato spoon reaches the accelerate point P, CPU2 sends a compensation control signal. After the compensation motor reaches the target speed for time  $t_a$ , the potato seed on the back of the 0<sup>#</sup> potato spoon will be precisely put into the seed drop gate, and a miss-seeding compensation can be completed. Then, the motor immediately shuts down, and the power of the seed-metering chain naturally returned to the ground wheel under the switch of one-way clutch. However, if the 1<sup>#</sup> potato spoon or other consecutive subsequent potato spoons also have no seeds, only data statistics and alarms will be performed, and no miss-seeding compensation will be performed. For the acquisition of  $t_a$ , it is calculated from the speed  $v_L$  of the seed-metering chain and the spoon distance  $L$ :

$$t_a = \frac{L}{v_L} \quad (5)$$

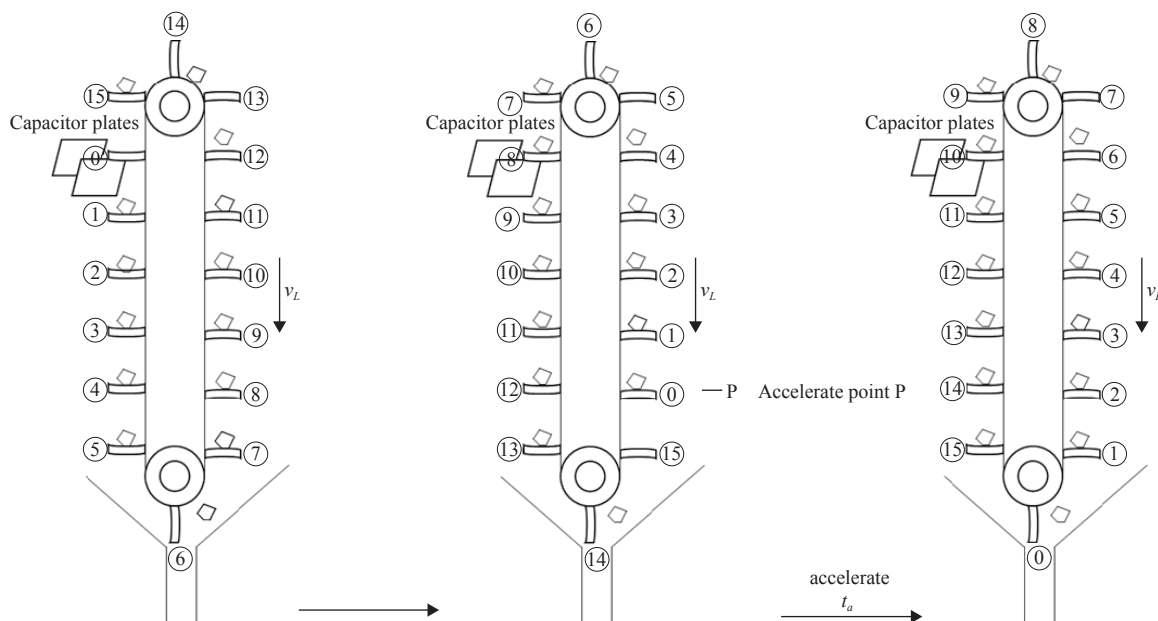

Figure 4 The improved catching-up compensation control scheme

### 2.2.3 Working logic of the new potato planter

In the routine operation of the potato planter, the miss-seeding

compensation actuator does not work. Through the main power transmission chain wheel and the land wheel power transmission

chain, the power on the land wheel axle reaches the seed-metering chain wheel axle II. In this case, CPU1, in conjunction with the spatial capacitance sensor, continuously obtains the maximum net capacitance fluctuation. The software judges the information of each passing potato spoon and calibrates its seed-loading status flag variable  $S(x)$ , at the same time, records the corresponding code of the grating encoder; CPU2 also continuously collects grating encoder data to capture the timing of miss-seeding compensation and calculates the seed-metering chain speed  $v_L$ , thereby, providing support for determining the target speed  $v'_L$  during the improved catching-up compensation [shown in Figure 5 and formula (6)]. The human-computer interaction system completes data input, sound-light alarming, and data display based on information such as CPU1, CPU2, and actual needs. The content of the data display section mainly includes:  $N_1$ , Natural sowing number;  $N_2$ , Natural miss-seeding number;  $N_3$ , Compensated sowing number;  $N_4$ , Final missed sowing number.

$$v'_L = 2k_x v_L, \quad k_x = [1.02, 1.10] \quad (6)$$

$$\Delta t_{a1} + \Delta t_{a2} = 0.1t_a, \quad (\Delta t_{a1} = \Delta t_{a2}) \quad (7)$$

where,  $k_x$  is the motion compensate coefficient empirically-determined.

However, when the system controller determines that there is a miss-seeding, through the communication interface, CPU2 can not only receive information such as seed-loading status flag variable  $S(x)$  and  $N_{1-4}$  from CPU1, but also obtain the code value of the grating encoder corresponding to the capacitance top value of the spatial capacitance sensor. Afterwards, CPU2 checks each time in its relevant timer service subroutine to see if the moment for miss-seeding compensation has arrived. If the timing has arrived and  $S(x+1)=1$  (the potato seed to be replenished available), CPU2 immediately issues a miss-seeding compensation command, and the compensation motor stops after completing the speed envelope as shown in Figure 5, with a running time of  $t_a$ . Subsequently, according to the working principle of the one-way clutch, the power of seed-metering chain wheel axle II will be switched back to the

land wheel axle, a complete improved catching-up compensation has been executed, and the potato planter will return to its normal operating state again.

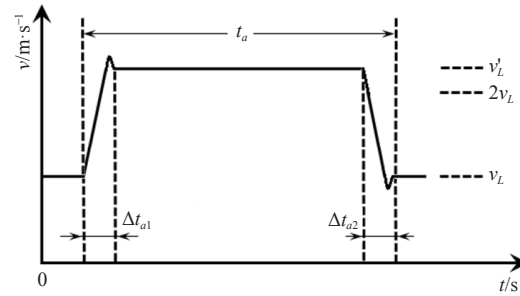

Figure 5 Seed-metering chain speed control in a typical catching-up compensation

### 3 Systems design

#### 3.1 Key hardware circuits

The core of the system controller lies in the acquisition of capacitance value, reading of grating encoder code, and generating of miss-seeding compensation control information. From the perspective of computational speed, reliability, and accessibility, both CPU1 and CPU2 can choose STM32F103. The key to obtaining capacitance value lies in its high frequency and sufficient accuracy. Based on the above content and theoretical calculations, as the theoretical value of the spatial capacitance sensor is less than 3pF, AD7745 is recommended to construct a separate measurement module close to the target. This not only improves accuracy as much as possible, but also greatly reduces the interference of stray capacitance. The AD7745 adopts on-chip CDC conversion and has the highest resolution of 1fF. The I<sup>2</sup>C bus is used between the AD7745 and CPU1 to obtain the capacitance measurement value of the spatial capacitance sensor at a 90Hz refresh rate. Therefore, at least, the seed-metering monitoring under medium and low operation conditions can be ensured. Its interface circuit can refer to Figure 6.

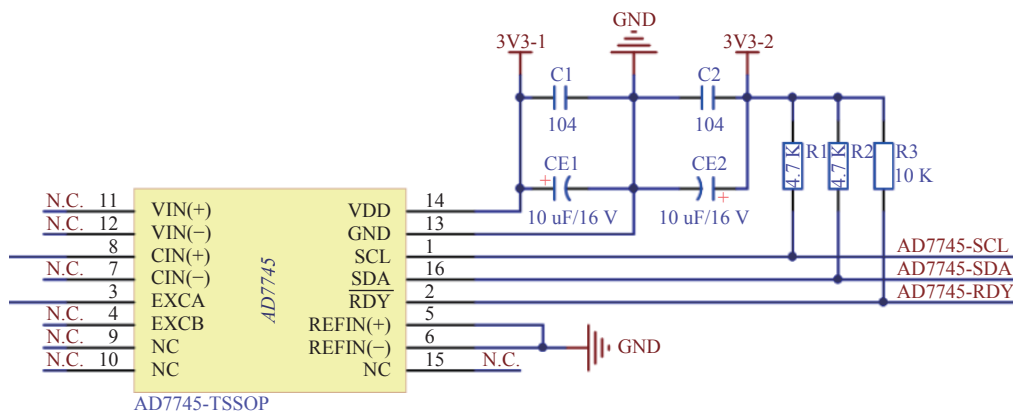

Figure 6 Interface circuit of AD7745

In addition, in grating encoder code reading and miss-seeding compensation control signal transmitting, in order to reduce the number of exposed signal cables and improve reliability, this study used RS-485 hardware to build a data channel. Specifically, compared to the previous generation technology of our research group (see reference<sup>[15-17]</sup>), the seed-monitoring of this project doesn't set fixed points, but instead, a continuous data acquisition scheme based on AD7745's 90Hz sampling is adopted. In this way, in order

to record the location information of miss-seedings, absolute value grating encoder is an inevitable choice. The multi-turn absolute value grating encoder used in this research has a single-turn resolution of 1024, and a total range of 16 384. Figure 7a shows that the signal is connected through socket P2, MAX3485 is in half-duplex working mode. In the figure, RO is used for data output and DI for data input. If ENC\_RE pin is at a high level, only data is allowed to flow in from DI; otherwise, only data is allowed to flow

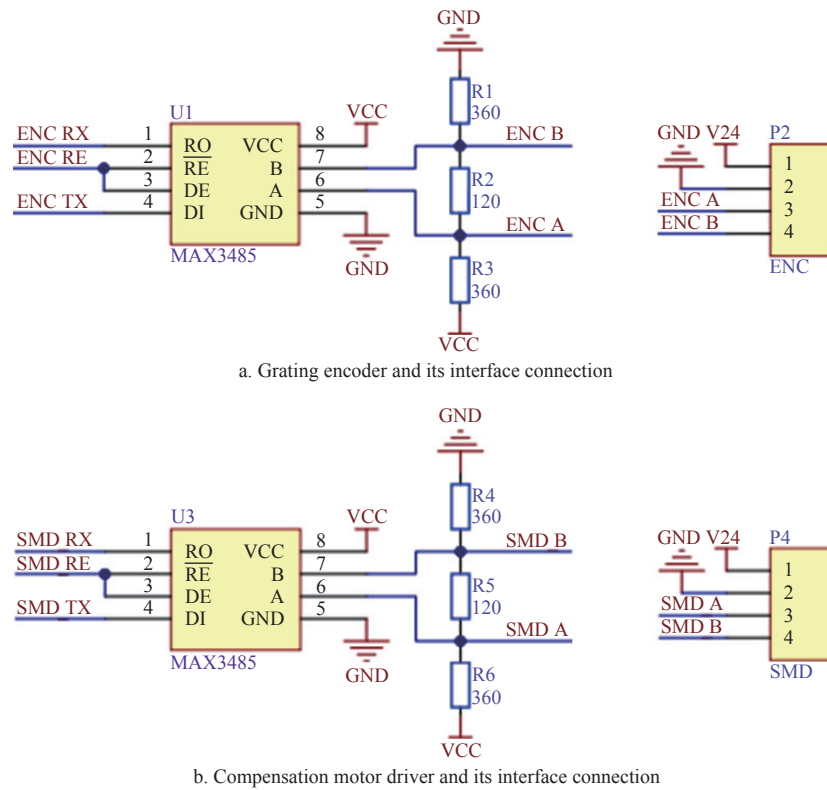

Figure 7 The main communication interface circuit of the system

out from RO. Resistors R1, R2, and R3 maintain the relative voltage between A and B within 6.5 V, thereby, the chip can be protected. Every time AD7745 data sampling is completed, the code of the absolute value grating encoder will be automatically read. The communication interface of the compensation motor driver is connected through port P4 (As shown in Figure 7b), but the transmission of miss-seeding compensation control information is based on the MODBUS standard frame format, which is consistent with the requirements of the compensation motor driver.

### 3.2 A potato seed-metering monitoring plan based on spatial capacitance sensor

According to the previous discussion, the miss-seeding judgment is based on the maximum net capacitance fluctuation. Assuming  $C$  is the real-time capacitance value of the spatial capacitance sensor obtained at a sampling speed of 90 Hz, based on Equations (1-4) and combined with Figure 8, the physical meaning of the net capacitance fluctuation can be further expressed as:

$$\Delta C = |C - C_1| \tag{8}$$

Therefore, the maximum net capacitance fluctuation can be unified as:

$$\Delta C_m = |C_m - C_1| \tag{9}$$

Here, parameter  $a$  needs to be defined first.

$$a = |C_u - C_1| \tag{10}$$

where,  $C_u$  is the maximum value of the spatial capacitance sensor under the no-spoon state. Compare  $\Delta C$  with  $a$ , and if  $\Delta C \leq a$ , it is considered as the normal fluctuation when the seed-metering chain passes through; If  $\Delta C > a$ , it is determined that the potato spoon has started entering the area surrounded by the capacitor plates, and each  $\Delta C$  value as well as its corresponding grating encoder code need to be recorded. Assuming that the value recorded each time is  $\Delta C_i$ , parameter  $b$  and  $c$  need to be introduced.

$$b = \Delta C_n - \Delta C_{n-1} \tag{11}$$

$$c = |C_e - C_u| \tag{12}$$

If  $b \geq 0$ ,  $C_n$  is recorded and prepared for the next comparison; if  $b < 0$ , the comparison is aborted, and  $\Delta C_{n-1}$  is compared to  $c$ .  $C_e$  is the maximum capacitance when the empty potato spoon is in the middle of the capacitor plate. If  $\Delta C_{n-1} \leq c$ , it is determined as miss-seeding, otherwise, it is believed a normal-seeding.

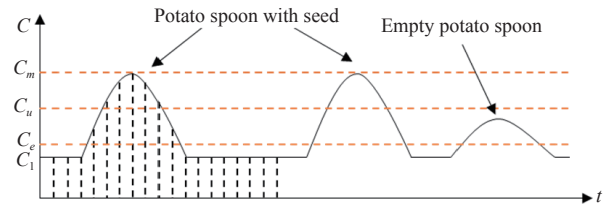

Figure 8 Capacitance value variation history of spatial capacitance sensor

However, there are several issues that need further clarification: 1)  $C_1$  and  $C_e$  are affected by factors such as temperature and humidity, so, they need to be updated in the CPU2 main program under certain conditions; 2) A threshold must be set to confirm that a potato spoon has entered the spatial capacitance sensor, so that, the system has the opportunity to modify the seed-loading status flag variable  $S(x)$  of the potato spoon at an appropriate time in the future; 3) Similarly, there must also be another threshold that can distinguish between normal-seeding and miss-seeding, and assign a value to the seed-loading status flag variable  $S(x)$  of the corresponding potato spoon based on it; 4) Of course, in this process, it is very important to find the top value measured by the spatial capacitance sensor and the corresponding absolute value grating encoder code, which will provide a basis for possible miss-seeding compensation signals. In summary, the monitoring software scheme for potato seed-metering monitoring system, which based on real-time capacitance value sampling using spatial capacitance sensor, can be referred to Figure 9.

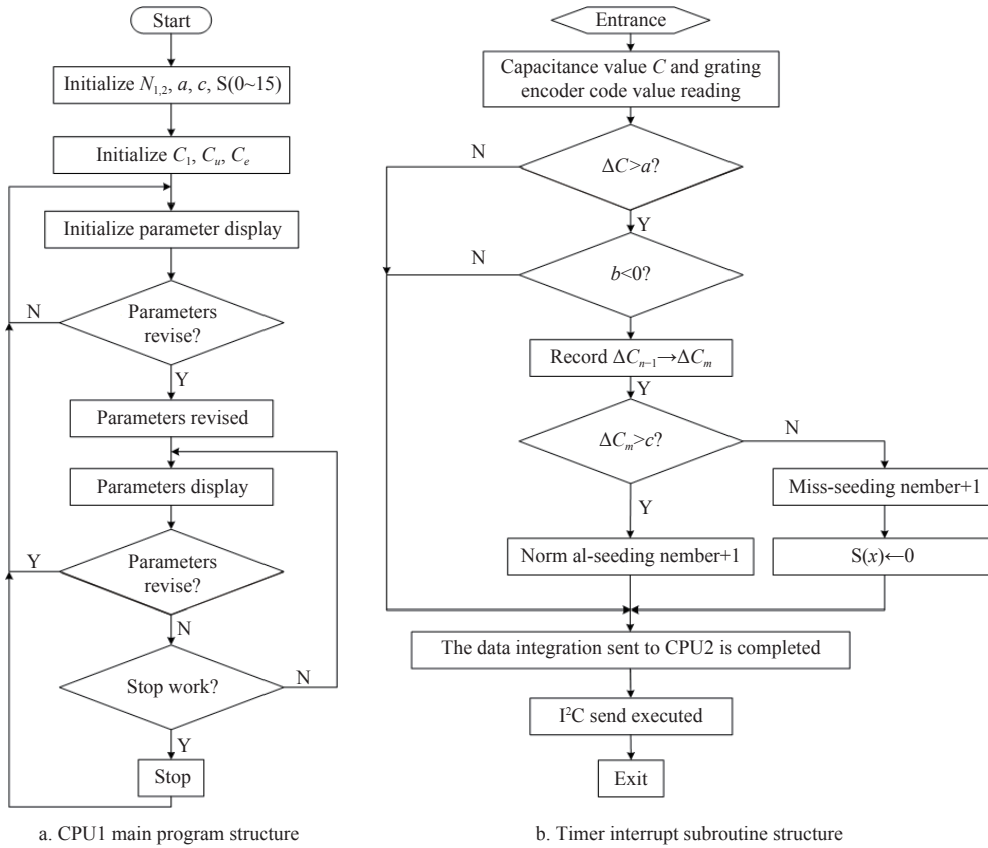

Figure 9 Block diagram of seed-metering status judgment program of CPU1

### 3.3 Software framework for the improved catching-up compensation

CPU2 belongs to the slave of CPU1 in terms of identity, responsible for communication data reading, key parameters calculating, and the compensation controlling. The software system mainly consists of a main program and a serial communication interrupt subroutine, the program structure diagram can be shown in Figure 10. Among them, Figure 10a shows the main program structure, it is responsible for tasks with low real-time performance, specifically including system initialization, parameter revision, statistical information display,  $v_L$  and  $C_1$  calculation; figure 10b, on the other hand, is related to the CPU1 information reading, classification, communication information storage, miss-seeding compensation execution, and statistical data update. Although the real-time performance of CPU2 is not as good as CPU1, it is particularly important for the successful implementation of miss-seeding compensation behavior, and its reliability is highly related to the operating results of CPU1. Therefore, the key links shown in Figure 11 need to be further stated as follows:

1) System initialization includes preparing the display screen and setting the initial values (i.e. default values) of the main parameters, such as  $a$ ,  $c$ ,  $N_1$ - $N_4$ ,  $k_x$ .

2) The purpose of parameter revision is to adapt to different working conditions and improve the reliability of system operation. The parameters that need to be revised include  $a$ ,  $b$ ,  $c$ , and  $k_x$ .

3) Display the latest  $N_1$ - $N_4$  values.

4)  $C_1$  is based on the average of the latest 100 stored numerical results to adapt the constantly changing specific temperature and humidity conditions. The specific execution criteria is

$$C_1 = 0.9C_{1n} + 0.1C_{1(n-1)} \quad (13)$$

where,  $C_{1n}$  is the average of the latest 100 stored numerical results, and  $C_1$  is the true value that this concept will be adopted in the next stage.

5) The calculation of  $v_L$  is based on the specific changes in the grating encoder code values corresponding to the two adjacent vertex capacitors, as each data transmission is based on a fixed time interval of 11.11 ms. It should be noted that, the calculation of  $v_L$  is arranged in the main program of CPU2, rather than in the serial communication interrupt subroutine of CPU1, because the real-time processing requirements of other data in the system are high, and the changes in seed-metering chain speed are usually slow relatively. The calculation of  $v_L$  in main program does not affect the system actual performance.

6) Non-stop parameters revision during normal operation can improve the system efficiency.

7) Data from CPU1 is read.

8) The communication data from CPU1 is classified and stored according to its physical meaning, including the shift of relevant data positions.

9) Because of miss-taking is discovered first, therefore, miss-seeding compensation will not carried out immediately, but must wait until the empty potato spoon reaches a specific position before proceeding. Nevertheless, due to the sampling of spatial capacitance sensor values every 11.11 ms, generally speaking, as long as the empty potato spoon is close enough to a specific position, miss-seeding compensation can begin, apparently, this will cause deviation in the landing point of the compensated seed potato.

10) If there is a seed potato on adjacent potato spoon after a missed one, it means that the compensation conditions are available; otherwise, it means that the compensation conditions are not met.

11) Here, only data  $N_3$  and  $N_4$  need to be updated.

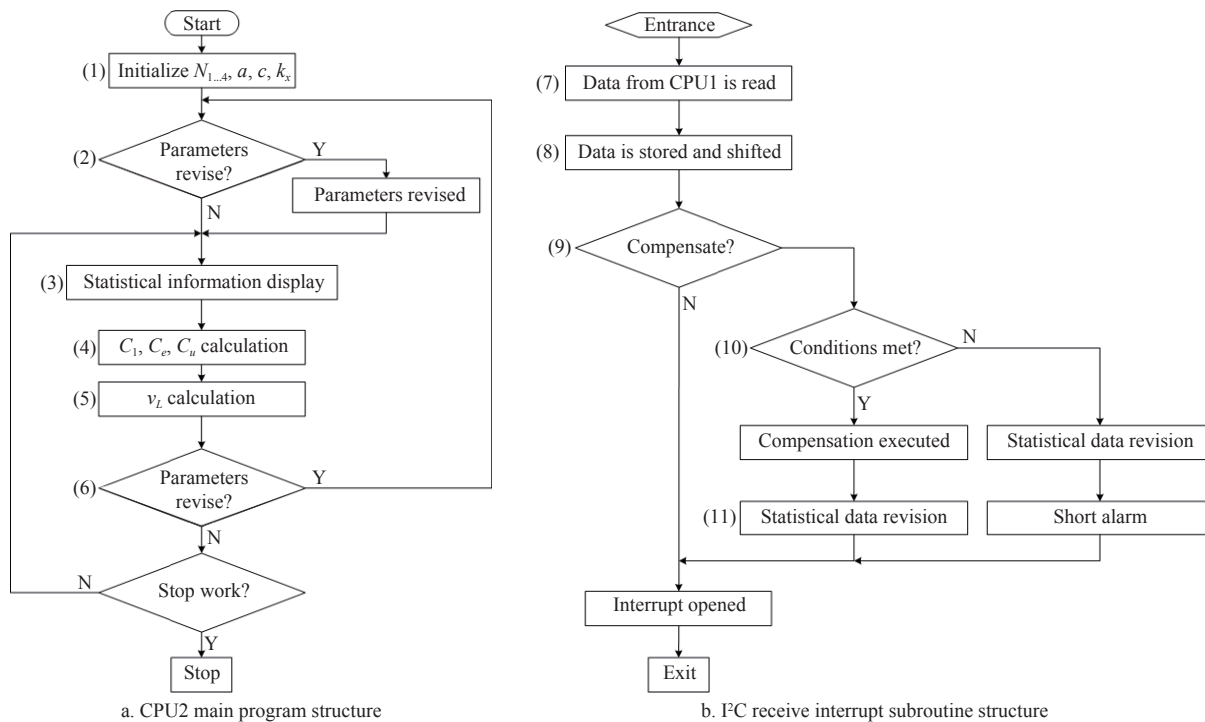

Figure 10 Block diagram of seed-metering status



Figure 11 Soil tank test of the prototype

4 Performance test

4.1 Equipment and materials

The prototype of this research was manufactured in the Agricultural Engineering Training Center of Gansu Agricultural University in early March 2023. The test material was cutting potato seeds, and the seed-metering chain speeds were selected as 0.2, 0.3, and 0.4 m/s, respectively. Its main purpose is to test the reliability of the miss-seeding detection and compensation system, as well as the accuracy of the latter. The main device parameters of the new potato planter are listed in Table 1.

4.2 Content and methods

This test was conducted on the soil tank platform of the base, simulating potato field planting, as shown in Figure 11. The tests were divided into two parts: compensation closed and fully functional operation. Repeat the test for each seed-metering chain speed level 3 times, with approximately 300 potato seeds tested each time. Among them, for compensation closed test, only the potato planter seed-metering, seed-metering state monitoring, and

Table 1 Main component parameters of the prototype

Device name	Model	Parameter
Control chip	STM32F103	Clock speed: 72 MHz; Flash capacity: 16 kB-1 MB
Spatial capacitance sensor	—	Dimensions: L60 mm (Arch height 5 mm), W60 mm (Distance between two arc centers), H45 mm
Compensation motor	86HBM80	Current: 6 A; Output torque: 8 N·m
Compensation motor driver	HBS86H	Subdivision setting: 800-51 200
Digital capacitor chip	AD7745	Resolution: 21bit; Measurement accuracy: 1 fF
Absolute value encoder	BH60Z8M12MB1	Resolution: 16×1024; communication: RS485
One-way clutch	CKA358532	4-point, 28 teeth, inner diameter 25 (08A)
Battery	6-QW-36(325)	Capacity: 100 A·h; Output voltage: 12 V

data statistics were involved, while the miss-seeding compensation function was disabled. The main purpose of this test was to detect the trend of changes in the monitoring results of system seed-metering and the accuracy of data statistics under simulated actual production conditions. The test results show that, with the seed-metering chain speed increases from 0.2 to 0.4 m/s, the average monitoring accuracy of the system also decreased from about 98.5% to 97.5% (the accuracy of data statistics was completely consistent with this). Although the decrease in this indicator was not significant, however, the range of miss-seeding monitoring to solve the problem usually does not exceed 7%. Therefore, the decrease in the average monitoring accuracy of the system can be considered severe. The reason is that, as the seed-metering chain speed increases, the obtained values of spatial capacitance sensor capacitor samples within a potato spoon length range will show a significant decrease, which will have an increasingly serious impact on the judgment of seed-metering status.

In the fully functional operation test, all functions of the system were put into use. The purpose was to verify the overall reliability of the system in a simulated field environment comprehensively.



Based on the judgment of seed-metering status and data statistics, this test will further execute miss-seeding compensation when the conditions were met. This test needed to calculate the following indicators based on obtaining  $N_1$ - $N_4$ , and another supplementary data  $N'_2$  (The true miss-seeding number, which is based on the statistical results of high-speed camera).

1) Natural field miss-seeding rate  $R$ , %;

$$R = \frac{N_2}{N_1} \times 100\% \quad (14)$$

2) Success rate of miss-seeding identification  $\eta_1$ , %;

$$\eta_1 = \frac{N_2}{N'_2} \times 100\% \quad (15)$$

3) Compensation success rate  $\eta_2$ , %;

$$\eta_2 = \frac{N_3}{N_2} \times 100\% \quad (16)$$

4) Final miss-seeding rate  $\eta_3$ , %;

$$\eta_3 = \frac{N_2 - N_3}{N_1} = \frac{N_4}{N_1} \times 100\% \quad (17)$$

### 4.3 Data and analysis

The test data obtained according to the test content and methods described in 4.2 are listed in Table 2.

**Table 2 The fully functional operation test result**

Chain speed/m·s <sup>-1</sup>	Tests	$N_1$	$N_2$	$N'_2$	$N_3$	$N_4$	$R/\%$	$\eta_1/\%$	$\eta_2/\%$	$\eta_3/\%$
0.2	1	302	19	19	18	1	6.29	100.00	94.74	0.33
	2	300	17	16	15	2	5.67	94.12	88.24	0.67
	3	299	13	13	13	0	4.35	100.00	100.00	0.00
0.3	1	290	21	20	17	4	7.24	95.24	80.95	1.38
	2	295	25	24	20	5	8.47	96.00	80.00	1.69
	3	298	20	20	18	2	6.71	100.00	90.00	0.67
0.4	1	290	25	23	20	5	8.62	92.00	72.00	2.41
	2	287	29	28	22	7	10.10	96.55	75.86	2.44
	3	286	35	33	28	7	12.24	94.29	77.14	2.45

The results of the fully functional operation test show that, with the seed-metering chain speed increases from 0.2 m/s to 0.4 m/s, the average value of natural field miss-seeding rate  $R$  increases from 5.44% to 10.32%, while the average value of success rate of miss-seeding identification  $\eta_1$  decreases from 98.04% to 94.28%. This indicates that, both the working performance of the potato seed-metering system itself and the seed-metering monitoring system based on spatial capacitance sensor are showing a more rapid deterioration trend. The reason for this is that, when improved catching-up compensation executes, the seed-metering chain speed will exceed twice the normal operating speed  $v_L$ , which makes the contradiction of AD7745 capacitor sampling speed limited more prominent. Therefore, the accuracy of seed-metering state judgment is not better than which under the compensation closed model. Whether the compensation can be successfully executed depends not only on the accurate judgment of miss-seeding, but also on the existence of the seed potatoes on the next potato spoon. In addition, with the seed-metering chain speed increases, the natural field miss-seeding rate  $R$  itself increases, combined with the additional miss-seeding opportunities brought about by improved catching-up compensation, the probability of potato seed absent on adjacent potato spoons will be sharply increased objectively. This will inevitably lead to a significant decrease in the compensation success rate  $\eta_2$  with the increase of the seed-metering chain speed. However, even when the seed-metering chain speed increases to 0.4 m/s, the

average value of compensation success rate  $\eta_2$  can still reach about 77%, which ensures that the average final miss-seeding rate  $\eta_3$  of the system at this time will not exceed 3.0%, the miss-seeding of the potato planter can be suppressed effectively.

The accuracy of the landing point for the compensated potato seed is the most intuitive manifestation of the compensation effect. The plant spacing in row of this potato planter has been fixed at 28 cm. Based on the distance between the compensated potato seed and the previous normal seed after successful compensation, a deviation greater than 20% of the standard spacing in row is set as deviate compensation, while a deviation less than 20% is believed as accurate compensation. The statistical data of the landing deviation of compensated potato seeds at different speeds are listed in Table 3.

**Table 3 Compensation accuracy statistics**

Chain speed/m·s <sup>-1</sup>	0.2			0.3 <sup>1</sup>			0.4		
Successful compensation	18	15	13	17	20	18	20	22	28
Accurate compensation	17	14	13	15	17	15	15	16	20
Deviate compensation	1	1	0	2	3	3	5	6	8
Precision compensation rate/%	94.44	93.33	100.00	88.24	85.00	83.33	75.00	72.73	71.43

The data listed in Table 3 shows that, the landing point deviation of the compensated potato seeds rapidly increases with the rise of the seed-metering chain speed, and its corresponding average precision compensation rate quickly decreases from 95.92% at a seed-metering chain speed of 0.2 m/s to 73.05% at 0.4 m/s. Although the reasons for this result are multifaceted, the complexity of the speed change process during compensation execution and the accuracy of the required time  $t_a$  calculation are the main factors that affect control accuracy. Therefore, in terms of the current control accuracy that this prototype can achieve, the maximum seed-metering chain speed can only be limited to 0.4 m/s.

## 5 Discussion

Although the innovation and feasibility of the concept described in this study have been proven by the above research, there are many problems in the implementation process, which are summarized as follows:

1) The AD7745 digital capacitor chip is used for miss-seeding detection, with a maximum sampling frequency of 90 Hz. Although it is faster than traditional capacitance detection methods, there is a problem of insufficient capacitance sampling at higher seeding speeds, which may miss the maximum point of capacitance, leading to misjudgment. Therefore, the seed-metering chain speed can only be limited to below 0.4 m/s now. Subsequent research can choose capacitor acquisition chips with higher sampling frequencies, or use interpolation prediction and other methods to improve the accuracy of maximum net capacitance fluctuation and corresponding grating encoder code to meet the objective needs of higher seed-metering chain speed.

2) The results of the soil tank test show that, along with the seed-metering chain speed increases, the success rate and accuracy of compensation decrease significantly, which is related to the mechanical motion inertia of the seed-metering chain during the acceleration of the catching-up compensation. Therefore, in terms of compensation, the mechanical structure of the seed-metering system can be further optimized, and the control parameters of the

compensation motor can be further adjusted to achieve higher success rates and accuracy.

3) The seed-metering monitoring system based on spatial capacitance sensors can not only determines miss-seeding, but also provides multi-seeding information. The key is to set a reliable threshold for the maximum net capacitance fluctuation. Although there may be some degree of misdetection for irregular cutting potato seeds, the vast majority of miss-seeding and multi-seeding can still be effectively identified. Consequently, multi-seeding inhibition is also an important research direction that has the opportunity to make breakthroughs, which is also an inevitable requirement for achieving precision potato sowing.

## 6 Conclusions

1) A capacitive miss-seeding detection scheme based on spatial capacitance sensor is proposed. It is built on the basis of the physical mechanism of different measured capacitance values between two fixed capacitor plates due to different media. The AD7745 high-precision chip is selected to collect the capacitance value of the spatial capacitance sensor, synchronously, the code of the grating encoder is also recorded together. With real-time capacitance measurement data obtained, during the process of each seed spoon passing through the space enclosed by the capacitor plates, the difference between the maximum capacitance measured under loaded and the no spoon states, i.e. the maximum net capacitance fluctuation, can be calculated and its position can be obtained too. At this point, a small threshold parameter can distinguish whether the seed spoon is sowing normally or a miss-seeding accident has occurred, laying a solid foundation for subsequent work.

2) Based on the accurate miss-seeding identification, a kind of improved catching-up compensation scheme is proposed. Due to the memory of the CPU, the restriction that the seed-metering monitoring point must be located at a specific position above the seed drop gate can be lifted. Therefore, this study not only allows the monitoring points to be located in the open area above the seed box, improving the monitoring environment, but also reduces the number of detection points from two to one. The most important thing is that, after a miss-seeding is detected, only the specific location information of their occurrence needs to be memorized first. Once the needed conditions are met, the catching-up compensation can be executed to reduce the difficulty of motion control.

3) The speed of the soil tank test was set to make the seed-metering chain to be 0.2, 0.3, and 0.4 m/s, respectively. It was found that, the long-term working accuracy of the miss-seeding detection system decreased with the increase of seed-metering chain, but still remained above 94%. The average success rates of the miss-seeding compensation system are 94.32, 83.65, and 75.00%, correspondingly, which decrease significantly with the seed-metering chain speed growth. However, after compensation, the final miss-seeding rate can still not higher than 3%, and the lowest precision compensation rate within the test range was not less than 70%, which has relatively high reliability and practicality.

## Acknowledgements

We are grateful for the support of the Industrial support plan of the Gansu Provincial Department of Education (Grant No. 2023CYZC-42), the National Natural Science Foundation of China (Grant No. 52165028) and the Key Scientific and the Technological Program of Gansu Province (Grant No. 22ZD6NA046).

## [References]

- [1] Huajing Industry Research Institute. Report on the development status and investment strategy of china's potato industry market from 2023 to 2029. 2023. Available: <https://www.huaon.com/channel/agriculture/886967.html>. Accessed on [2024-03-11]. (in Chinese)
- [2] Dai F, Song X F, Zhao W Y, Shi R J, Zhang F W, Zhang X K. Mechanism analysis and performance improvement of mechanized ridge forming of whole plastic film mulched double ridges. *Int J Agric & Biol Eng*, 2020; 13(5): 107–116.
- [3] Sun W, Simionescu P A. Parameter analysis and field tests of a double crank multi-rod under plastic-film hill-drop mechanism potato planter. *American Journal of Potato Research*, 2020; 97: 256–264.
- [4] Zhu L Y. Design and test of 2CM-2 potato ridging-filming-sowing machine. Master dissertation. Yangling: Northwest A&F University, 2017; 67 p. (in Chinese)
- [5] Li D, Sun W, Shi L R, Zhang H, Liu X L, Wu J M. Parameter simulation design and experiment of crossing device of covering soil on film. *Agricultural Research in the Arid Areas*, 2018; 36(1): 281–287. (in Chinese)
- [6] Aboegela M A, El-Ghobashy H M, Shaban Y A. Development a single row potato planter for small holdings. *Journal of Soil Sciences and Agricultural Engineering*, 2021; 12(3): 137–143.
- [7] Sun W, Liu X L, Zhang H, Wang H C, Tian B. Design of potato casingsoil planter in all-in-one machine combined with fertilizing, sowing, ridging, complete film mulching and planting line covering. *Transactions of the CSAE*, 2017; 33(20): 14–22. (in Chinese)
- [8] Li P, Feng W, Zhang X F, Zhong W R, Wang P, Cui J B. Study on missed sowing monitoring and reseeded system design of potato planter. *Journal of Agricultural Mechanization Research*, 2023; 45(12): 81–88. (in Chinese)
- [9] Suomi P, Oksanen T. Automatic working depth control for seed drill using ISO11783 remote control messages. *Computers & Electronics in Agriculture*, 2015; 116: 30–35.
- [10] Wang S, Sun Y H, Yang C, Yu Y C. Advanced design and tests of a new electrical control seeding system with genetic algorithm fuzzy control strategy. *Journal of Computational Methods in Sciences and Engineering*, 2021; 21(3): 703–712.
- [11] Mhango J K, Harris E W, Green R, Monaghan J M. Mapping potato plant density variation using aerial imagery and deep learning techniques for precision agriculture. *Remote Sensing*, 2021; 13(14): 2705.
- [12] Zhang X D, Wu J M, Sun W, Wang D. Design of automatic compensation system for potato planter. *Journal of Gansu Agricultural University*, 2013; 48(1): 145–149, 155. (in Chinese)
- [13] Liu Q W, Wu J M, Wang D, Sun W, Wang G P, Shi L R, et al. Design and test of a microcomputer-controlled loss sowing compensation system for 2CM-2 potato seeder. *Agricultural Research in the Arid Areas*, 2013; 31(3): 260–266. (in Chinese)
- [14] Sun W, Wang G P, Wu J M. Design and experiment on loss sowing testing and compensation system of spoon-chain potato metering device. *Transactions of the CSAE*, 2016; 32(11): 8–15. (in Chinese)
- [15] Wang G P, Sun W. Development of a kind of potato loss sowing detection and compensation device. *Research of Agricultural Modernization*, 2016; 37(5): 1008–1014. (in Chinese)
- [16] Wang G P, Sun W, Chen L D, Zhang H, Liu X L, Li H L, et al. Realization of an integrated seeding and compensating potato planter based on one-way clutch. *Int J Agric & Biol Eng*, 2020; 13(3): 79–87.
- [17] Wang G P, Sun W, Zhang H, Liu X L, Li H L, Yang X P, et al. Research on a kind of seeding-monitoring and compensating control system for potato planter without additional seed-metering channel. *Computers and Electronics in Agriculture*, 2020; 177: 105681.
- [18] Zhou L M, Zhang X C, Yuan Y W. Design of capacitance seed rate sensor of wheat planter. *Transactions of the CSAE*, 2010; 26(10): 99–103. (in Chinese)
- [19] Zhou L M, Wang S M, Zhang X C, Yuan Y W, Zhang J N. Seed monitoring system for corn planter based on capacitance signal. *Transactions of the CSAE*, 2012; 28(13): 16–21. (in Chinese)
- [20] Niu K, Zhou L M, Yuan Y W, Liu Y C, Fang X F. Design and experiment on automatic compensation system of spoon-chain potato metering device. *Transactions of the CSAM*, 2016; 47(S1): 76–83. (in Chinese)
- [21] Zhang H, Zhao W Y, Sun W, Wang G P, Liu X L, Feng B, et al. Potato planter test bed based on capacitive precision seed-monitoring and miss-seeding compensation system. *Int J Agric & Biol Eng*, 2022; 15(6): 104–112.